

## ML7421A,B Electric Linear Valve Actuator

### PRODUCT DATA



### FEATURES

- Quick and easy installation.
- No separate linkage required.
- 3/4 in. (20 mm) stroke on ML7421A;  
1-1/2 in. (38 mm) stroke on ML7421B.
- No adjustments required.
- Accurate valve positioning.
- Low power consumption.
- High close-off ratings.
- Force-limiting end switches.
- Manual operator.
- Synchronous motor.
- Corrosion-resistant design.
- Maintenance free.
- Conduit connector knockout.

### APPLICATION

The ML7421A,B Electric Linear Valve Actuators are modulating control motors for use with low-voltage controls that provide an analog output of 0 to 10 Vdc or 2 to 10 Vdc. These actuators operate standard Honeywell valves in heating, ventilating, and air conditioning (HVAC) applications.

### Contents

Application .....	1
Features .....	1
Specifications .....	2
Ordering Information .....	2
Installation .....	3
Operation .....	6
Checkout .....	7



## SPECIFICATIONS

### Models:

Model No.	Description	Signal Input	Stroke in in. (mm)	Run Time in sec at 60 Hz
ML7421A1008	Electric Linear Valve Actuator	2 to 10 Vdc or 0 to 135 ohm	3/4 (20)	95
ML7421A1024		0 to 10 Vdc	3/4 (20)	95
ML7421B1007		2 to 10 Vdc or 0 to 135 ohm	1-1/2 (38)	175
ML7421B1015		0 to 10 Vdc	1-1/2 (38)	175

### Electrical Ratings:

Power Input: 24 Vac (+10%, -15%), 60 Hz.  
Power Consumption: 12 VA maximum at 24 Vac.

### Stem Force:

405 lbf (1800N).

### Ambient Temperature Range:

14°F to 122°F (-10°C to +50°C).

### Storage Temperature Range:

-40°F to +158°F (-40°C to +70°C).

### Humidity:

5 to 95 percent relative humidity, noncondensing.

### Close-off Pressure Ratings:

See Tables 1 and 2.

### Protection Standard:

IP54.

### Insulation:

Class I (24 Vac).

### Approvals:

UL94-5V Flame Retardant.  
Meets CE standards.

### Cable entry:

Two knockout holes for 1/2 in. and 3/4 in. conduit standard on actuator case.

### Actuator Material:

Cover: ABS plastic.  
Yoke and Base: Diecast aluminum.

### Weight:

5.1 lb (2.3 kg).

### Dimensions:

See Fig. 1.

### Accessories:

NOTE: The following dual auxiliary potentiometers can be added but provide only a single auxiliary potentiometer function.

43191679-103 Dual 220 Ohm Auxiliary Potentiometer for ML7421A.

43191679-104 Dual 220 Ohm Auxiliary Potentiometer for ML7421B.

43191680-102 Dual Auxiliary Switch for ML7421A,B (for 24 Vac use only).

43196000-101 High Temperature Kit. Includes 1/4 in. and 3/8 in. stem extenders. The kit increases the temperature range to 428°F (220°C).

## ORDERING INFORMATION

When purchasing replacement and modernization products from your TRADELINE® wholesaler or distributor, refer to the TRADELINE® Catalog or price sheets for complete ordering number.

If you have additional questions, need further information, or would like to comment on our products or services, please write or phone:

1. Your local Home and Building Control Sales Office (check white pages of your phone directory).
2. Home and Building Control Customer Logistics  
Honeywell Inc., 1885 Douglas Drive North  
Minneapolis, Minnesota 55422-4386 (612) 951-1000

In Canada—Honeywell Limited/Honeywell Limitée, 155 Gordon Baker Road, North York, Ontario M2H 2C9.

International Sales and Service Offices in all principal cities of the world. Manufacturing in Australia, Canada, Finland, France, Germany, Japan, Mexico, Netherlands, Spain, Taiwan, United Kingdom, U.S.A.

Table 1. Close-off Ratings in psi for ML7421A,B Electric Linear Valve Actuators and V5011, V5013 Valves.

Valve	Type	1/2 in.	3/4 in.	1 in.	1-1/4 in.	1-1/2 in.	2 in.	2-1/2 in.	3 in.	4 in. <sup>a</sup>	5 in. <sup>a</sup>	6 in. <sup>a</sup>
V5011A	Flange	N/A	N/A	N/A	N/A	N/A	N/A	77	53	29	18	12
V5011B	Flange	N/A	N/A	N/A	N/A	N/A	N/A	N/A	N/A	29	18	12
V5011F	Screw	150	150	150	150	150	150	100	61	N/A	N/A	N/A
V5011G	Screw	150	150	150	150	150	150	100	61	N/A	N/A	N/A
V5013B	Flange	N/A	N/A	N/A	N/A	N/A	N/A	77	53	29	18	12
V5013C	Flange	N/A	N/A	N/A	N/A	N/A	N/A	77	53	29	18	12
V5013F	Screw	150	150	150	150	150	150	N/A	N/A	N/A	N/A	N/A

<sup>a</sup> Only for use with ML7421B Actuator.

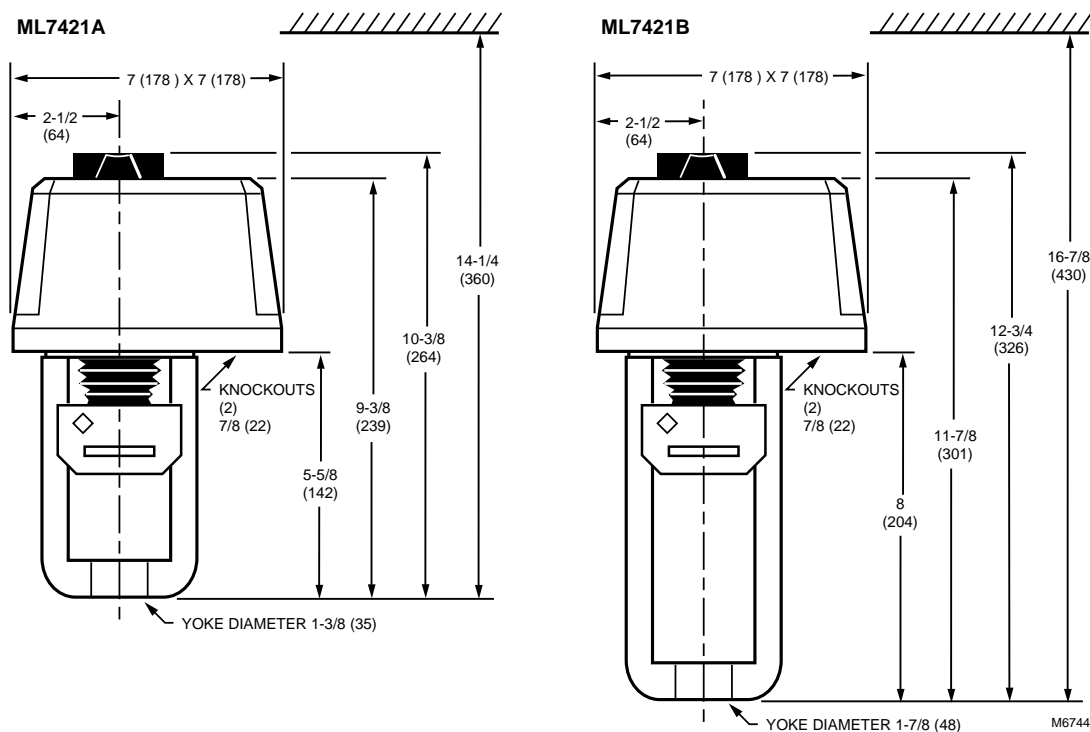

Fig. 1. Approximate dimensions of ML7421A,B Electric Linear Valve Actuator in in. (mm).

Table 2. Close-off Ratings in psi for ML7421A,B Electric Linear Valve Actuators and V3350,1; V3361; V3450,1; V3460,1 Valves.

Valve Model	Valve Size in in.	Close-Off Rating psi (kPa) <sup>a</sup>
		404 lbf (1800N)
V3350, V3351, V3460, V3461,	2-1/2	63 (434)
	3	45 (310)
V3350, V3351, V3450, V3451	4 <sup>b</sup>	25 (172)
	5 <sup>b</sup>	16 (110)
	6 <sup>b</sup>	11 (76)

<sup>a</sup> Represents maximum pressure difference between the outlet and either of the two inlets.

<sup>b</sup> Only for the use with ML7421B Actuator.

## INSTALLATION

### When Installing this Product...

1. Read instructions carefully. Failure to follow them could damage the product or cause a hazardous condition.
2. Check ratings and description given in the specifications to make sure the product is suitable for your application.
3. Installer must be a trained, experienced service technician.
4. After installation is complete, check out product operation as provided in these instructions.

### CAUTION

Disconnect power before installation to prevent electrical shock or equipment damage.

### Location

Install the actuator in a location that allows enough clearance for mounting accessories and for servicing. See Fig. 1.

## ⚠ CAUTION

Do not install actuator in a position below horizontal to minimize risk of damage to the actuator in the event of condensation or a valve gland leak.

## Mounting

NOTE: Check valve body literature for valve stem button adjustment dimension.

- 1 Attach the actuator to the valve collar and tighten the set screws with a 5/32 in. (4 mm) hex wrench.

### IMPORTANT

When tightening the set screws, first tighten the right set screw. See Fig. 2.

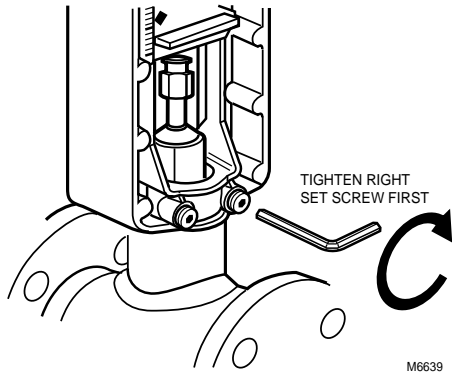

Fig. 2. Attaching actuator to valve collar.

- 2 Push in the stem button retaining clip and hold. See Fig. 3.

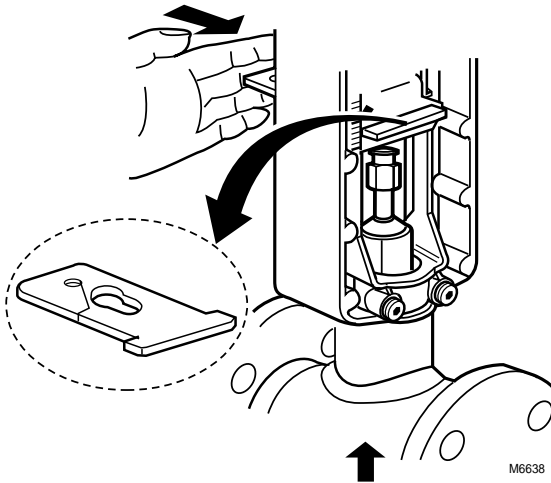

Fig. 3. Attaching actuator to valve stem.

- 3 Lift the valve stem until the head of the valve stem button is inside the large slot of the stem button retaining clip on the actuator.
- 4 Release the stem button retaining clip to secure the stem button.
- 5 Check to ensure that retaining clip holds the stem button in place.
- 6 Pull off the manual operation knob, loosen the cover screws, and remove the actuator cover.

## Wiring

## ⚠ CAUTION

Disconnect power supply before wiring to prevent electrical shock or equipment damage.

All wiring must comply with local electrical codes, ordinances, and regulations. Voltage and frequency of the transformer used with the ML7421 must correspond with the characteristics of the power supply and those of the actuator.

- 1 Feed the power and control wires through the opening on the bottom of the actuator case.
- 2 Using the wiring diagrams in Fig. 4 through 9, connect the power and control wires to the ML7421. Make sure that all wiring is correct.
- 3 When wiring and checkout are complete, replace the cover, tighten the cover screws, and replace the manual operator knob, Fig. 10.
- 4 Apply power and control signals to the ML7421.

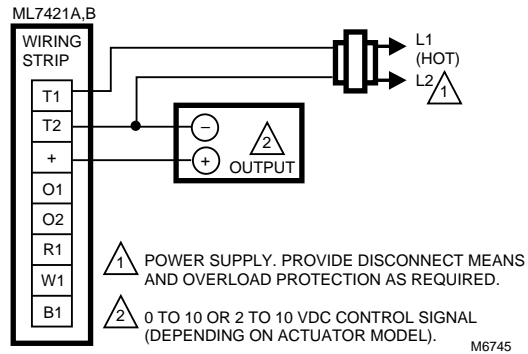

Fig. 4. ML7421 typical wiring diagram.

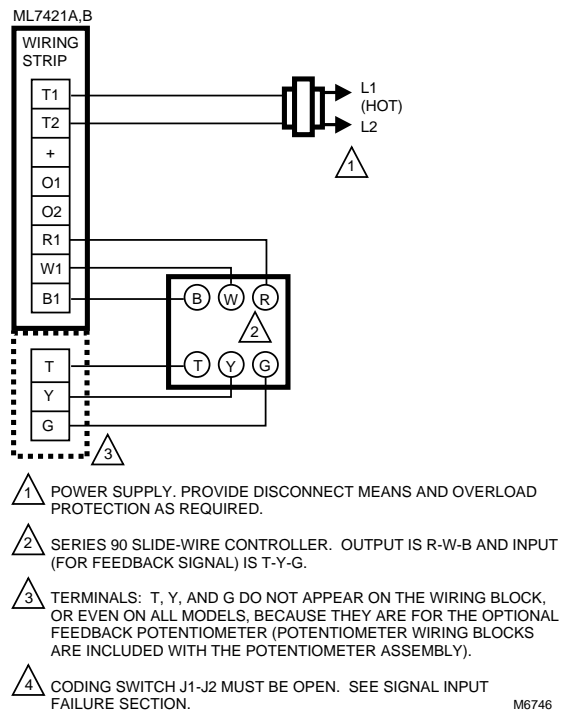

Fig. 5. ML7421 with 0 to 135 ohm input wiring diagram.

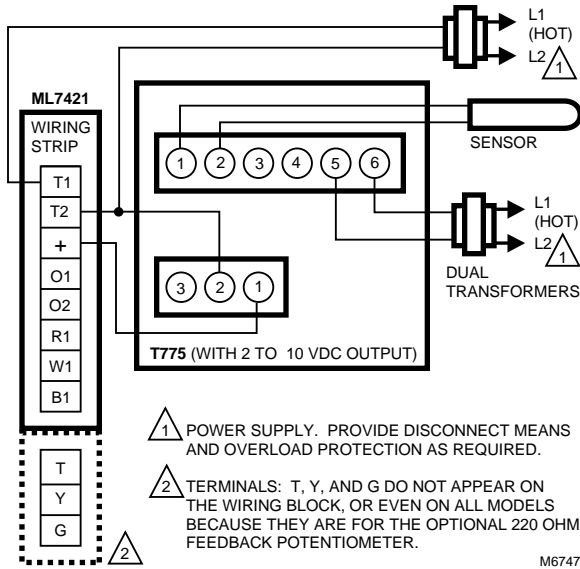

Fig. 6. ML7421 wiring diagram using a 2 to 10 Vdc output control (e.g., T775) with two transformers.

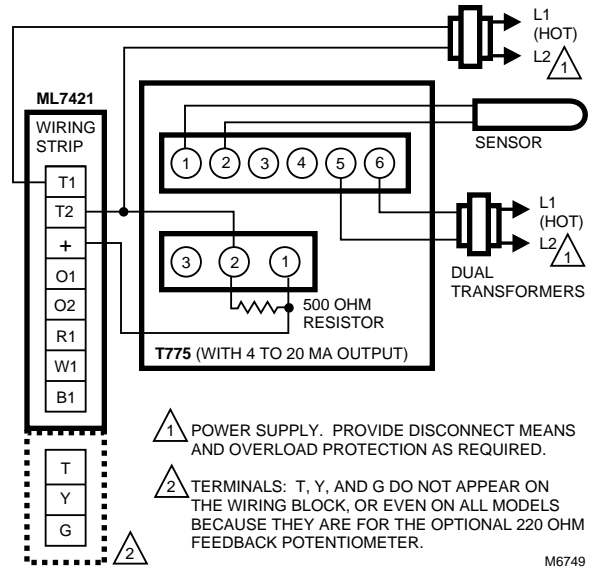

Fig. 8. ML7421 wiring diagram using a 4 to 20 mA output control (e.g., T775) with two transformers.

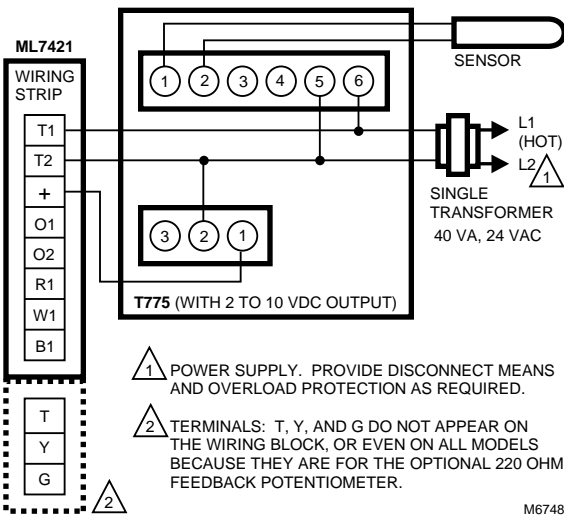

Fig. 7. ML7421 wiring diagram using a 2 to 10 Vdc output control (e.g., T775) with one transformer.

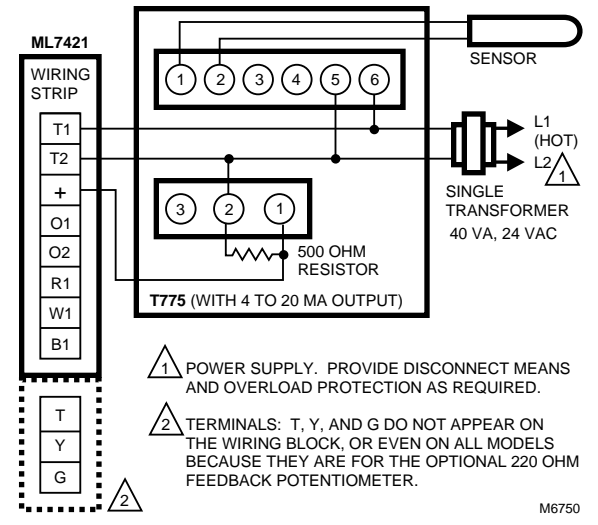

Fig. 9. ML7421 wiring diagram using a 4 to 20 mA output control (e.g., T775) with one transformer.

### Auxiliary Potentiometers

The 43191679 Dual 220 Ohm Auxiliary Potentiometer can be used as feedback potentiometers and to provide remote indication of the valve position. This dual potentiometer must be used but will provide only a single auxiliary potentiometer function with feedback of 135 ohm operating range. See the Accessories section for the part numbers and the Installation Instructions packed with the potentiometer for further details.

### Auxiliary Switches

The 43191680 Dual Auxiliary Switch can be used on both the ML7421A and ML7421B Electric Linear Valve Actuators. Switching points are adjustable over the full length of the actuator stroke; for example, the switch can be used to switch pumps or to provide remote indication of any stroke position. See the Accessories section for the part numbers and the Installation Instructions packed with the auxiliary switches for details.

**IMPORTANT**

*Use the 43191680 Dual Auxiliary Switch only with 24 Vac applications.*

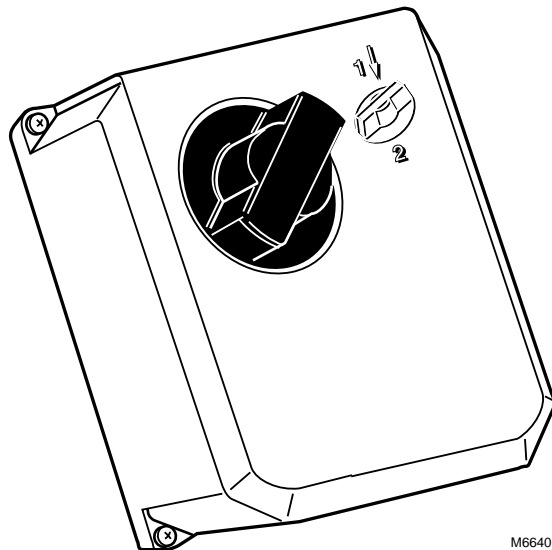

Fig. 10. ML7421A,B manual operator knob.

## OPERATION

### General

In the ML7421, the drive of a synchronous motor is converted into the linear motion of the actuator stem by using a worm gear transmission. A button retainer clip connects the actuator stem to the valve stem.

The internal force sensor, using installed microswitches, turns off the actuator when the specified stem force is reached.

### Manual Operation

The ML7421 is equipped with a manual operator knob (see Fig. 10) to open or close the valve in the event of power failure. Turn off or disconnect the power supply before manually operating the ML7421.

To operate, push down on the manual operator knob and turn the knob counterclockwise to move the stem downward or turn the knob clockwise to move the stem upward. When the actuator is returned to automatic control, the manual operator knob unlocks automatically.

**NOTE:** If the manual operator knob is not pushed in while turned, it turns only for a short distance before it automatically disengages without power resumption.

**IMPORTANT**

*Manual operation allows a very high closing force that can jam the actuator spindle, exceeding the rating of the force switches, and stopping the motor. After a manual valve close-off operation, release the spindle one turn by turning the manual operator knob so the manual operator automatically disengages on power resumption.*

### Signal Input Failure

Using coding switch J1-J2, the actuator can be set to run to one of three positions in the event of a signal failure:

- ❶ Coding switch open:  
The actuator goes to the middle position on signal input (+) failure.
- ❷ Coding switch in the upper position (J1):  
The actuator goes to the upper position on signal input (+) failure.
- ❸ Coding switch in the lower position (J2):  
The actuator goes to the lower position on signal input (+) failure.

The coding switch is a hook-type switch mounted on the component side of the printed circuit board. See Fig. 11.

**IMPORTANT:**

*If the actuator (ML7421A1008 or ML7421B1007 only) is used with a Series 90, 135-ohm controller, the coding switch must be open.*

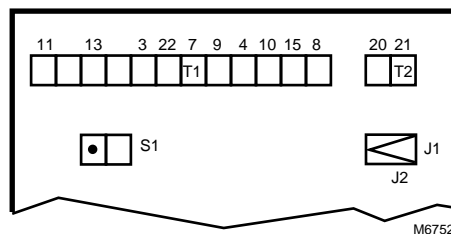
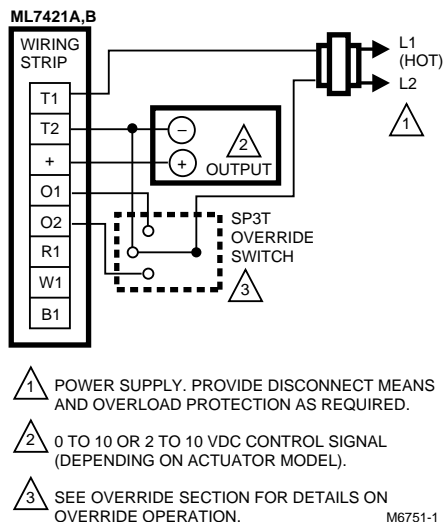

Fig. 11. Coding switch position and direction of action.

## Actuator Override

The converter output signal override function can be used in freeze protection or similar applications. It forces the actuator to a specific position, overriding the control signal. To exercise this function, disconnect the 24 Vac common from the actuator (T2) and connect it to Terminal O1 or O2. Connecting to Terminal O1 fully extends the actuator stem (bottom stem position). Connecting to Terminal O2 fully retracts the actuator stem (upper stem position).

The control signal (+) is ignored when the override signal is applied to Terminal O1 or O2. This override can be achieved with a switch or relay. See Fig. 12.



**Fig. 12. Connections for overriding the control signal to drive the actuator to a specific position.**

## Direction of Action

The direction of action can be changed by repositioning the Selector Switch S1 on the component side of the printed circuit board (see Fig. 11) for the 0 to 10 Vdc models only (ML7421A1024 and ML7421B1015). It is factory set so the stem extends (bottom stem position) at increasing signal and retracts (upper stem position) at decreasing signal.

The 2 to 10 Vdc models (ML7421A1008 or ML7421B1007) are not furnished with a selector switch. Reverse the operation of these actuators by reversing the signal from the controller.

## CHECKOUT

The ML7421 Electric Linear Valve Actuator can be checked out either directly or using a controller.

### Direct Checkout

- 1 Mount the actuator for the required application.
- 2 Check the valve position and make sure that 24 Vac is correctly applied to the actuator.
- 3 Apply the control signal to the appropriate leadwires to move the valve in the required direction.
- 4 If the actuator does not move, make sure the actuator is properly installed.
- 5 If the actuator is correctly installed and still does not run, replace the actuator.

### Controller Checkout

- 1 Adjust the setpoint of the controller to call for opening or closing the valve. Observe the actuator.
- 2 If the valve is closed, it should begin to open.
- 3 If the valve remains closed, move the setpoint further toward the open setting.
- 4 If the valve still does not move, check for 24 Vac in the actuator power input.
- 5 If 24 Vac is present and the actuator does not operate, reverse the controller leadwires to determine if the device is miswired.
- 6 If the wiring is correct, 24 Vac is present on the power input terminals and the actuator does not run, replace the actuator.

**Home and Building Control**

Honeywell Inc.  
Honeywell Plaza  
P.O. Box 524  
Minneapolis MN 55408-0524

**Honeywell Latin American Division**

Miami Lakes Headquarters  
14505 Commerce Way Suite 500  
Miami Lakes FL 33016

**Home and Building Control**

Honeywell Limited-Honeywell Limitée  
155 Gordon Baker Road  
North York, Ontario  
M2H 2C9

**Honeywell Europe S.A.**

3 Avenue du Bourget  
B-1140 Brussels Belgium

**Honeywell Asia Pacific Inc.**

Room 3213-3225  
Sun Hung Kai Centre  
No. 30 Harbour Road  
Wanchai  
Hong Kong

---

**Honeywell**