

me

COPPER TUBE



COPPER TUBE

FOR PLUMBING REFRIGERATION & AIR CONDITIONING

ASTM Standard



Introduction

Since before the dawn of history—when primitive man first discovered copper—the red metal has constantly served the advancement of civilization. Archeologists, probing ancient ruins, have discovered that this enduring metal was a great boon to many peoples. Tools for handicraft and agriculture, weapons for hunting, and articles for decorative and household uses were wrought from copper by early civilizations.

The craftsmen who built the great pyramid for the Egyptian Pharaoh, Cheops, fashioned copper pipe to convey water to the royal bath. A remnant of this pipe was unearthed some years ago, still in usable condition, a testimonial to copper's durability and resistance to corrosion.

Modern man, recognizing that no material is superior to copper for conveying water, has re-established it as the prime material for such purposes. Years of trouble-free service in installations here and abroad have gained a new reputation for copper piping in its modern form—light, strong, corrosion resistant tube. It serves all kinds of buildings: single-family homes, high rise apartments, and industrial, commercial, and office buildings.

Today, copper tube for the plumbing, heating, and air conditioning industries is available in drawn and annealed tempers (referred to in the trades as "hard" and "soft") and a wide range of diameters and wall thicknesses. Readily available fittings serve every design application. Joints are simple, reliable, and economical to make—additional reasons for selecting copper tube.

Today, nearly 5,000 years after Cheops, copper developments continue as the industry pioneers broader uses for copper tube in engineered plumbing systems for new and retrofitted residential, industrial, and commercial installations.

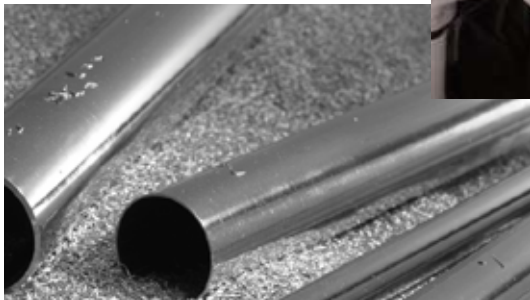

ASTM Standard 

Copper Cathode Melting

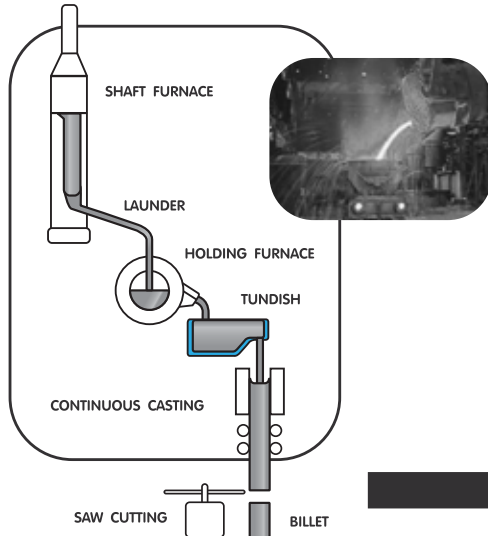

MANUFACTURING PROCESS

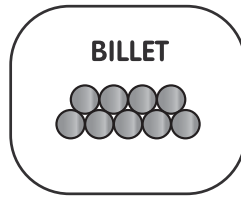

Extrusion

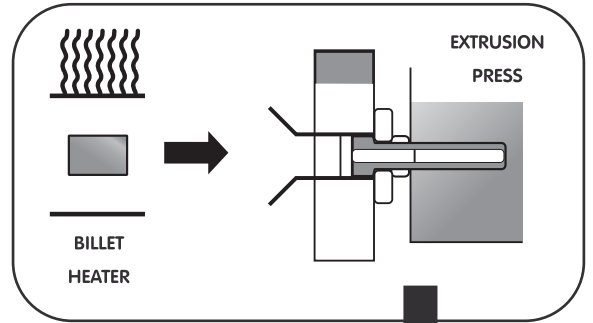

Rolling, Drawing, Re-rolling

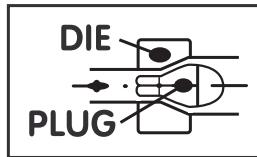
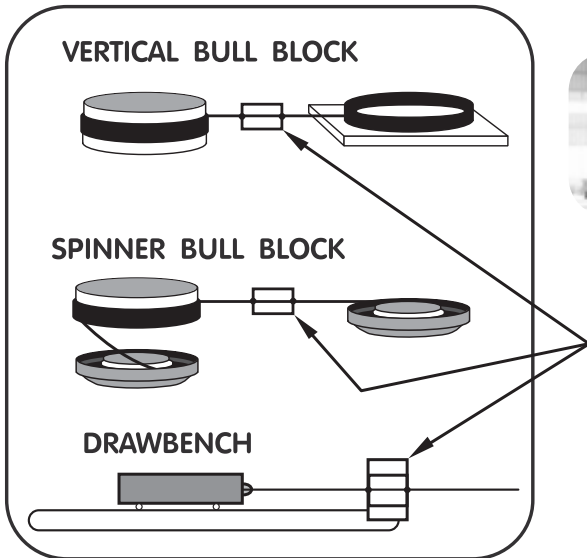

Finishing

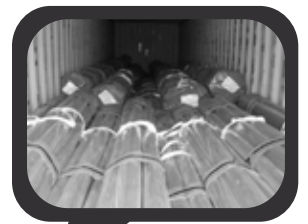
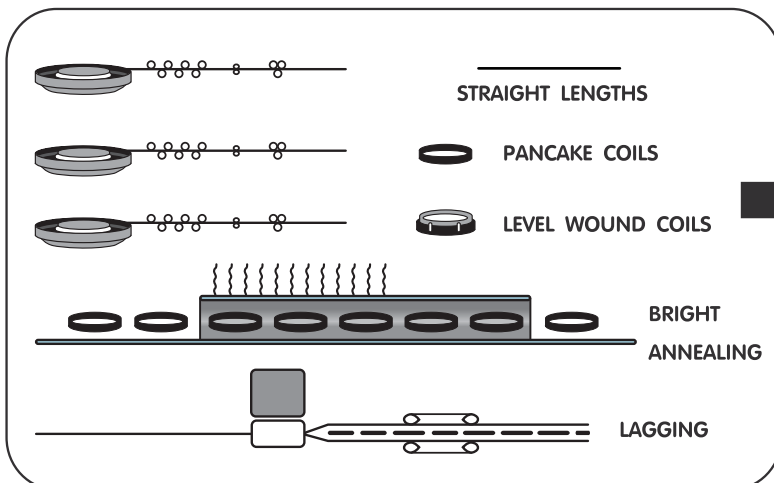

Packing & Delivery

Types of copper tube

There are two principal classes of copper tube. The first is commonly referred to as plumbing tube and includes Types K, L, M, and DWV. The second is ACR tube, for air conditioning and refrigeration field service.

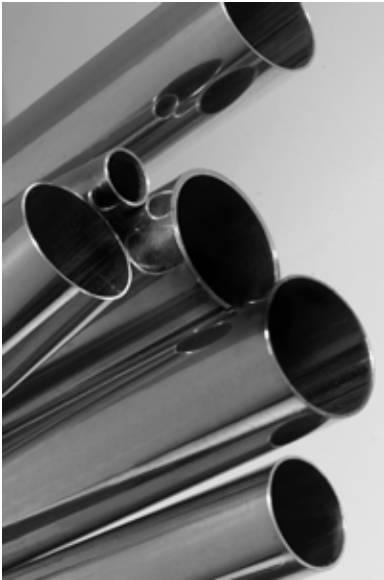

These classes and types of tube are commercially available in the tempers and lengths described in Table 1.

Types K, L, M, and DWV are designated by ASTM standard size, with the outside diameter always $\frac{1}{8}$ -inch larger than the standard size. Each type (K, L, M, and DWV) represents a series of sizes with different wall thicknesses. The inside diameters depend on tube size and wall thickness. All four types are available in drawn temper in straight lengths ordinarily 20 feet long. Type K, L and M are available also in annealed temper in 20-ft straight lengths or in long coils in sizes from $\frac{1}{4}$ -inch to 2-inch.

Copper tube for air conditioning and refrigeration field service (ACR tube) is designated by its actual outside diameter. It is available in soft annealed coils or hard-drawn lengths. It is intended for use in the field with special fittings for connections, repairs, and alterations in air conditioning and refrigeration installations.

In the piping trades, drawn tube is often referred to as “hard” tube, and annealed tube as “soft” tube. Drawn tube is also furnished in a “bending temper.” This light-drawn temper of intermediate strength and hardness may be specified for applications requiring bending. Tube in the hard temper condition can be joined by soldering or brazing, using capillary fittings, or by welding. Tube in the bending and soft tempers can be joined by the same techniques and also by the use of flare-type compression fitting. It is also possible to expand the end of one tube so that it can be joined to another by soldering or brazing without a capillary fitting—a procedure that can be efficient and economical in many installations.

TABLE 1 Copper Tube : Types, Standards, Application, Tempers, Lengths

Tube Type	Standard	Application	Commercially Available Lengths Nominal or Standard Size
TYPE K	ASTM B 88	Domestic Water Service and Distribution, Fire Protection, Solar, Fuel/Fule Oil, HVAC, Snow Melting	STRAIGHT LENGTHS:
			1/4-inch to 8-inch 10-inch 12-inch
			COILS:
			1/4-inch to 1-inch 1 1/4-inch and 1 1/2-inch 2-nch
TYPE L	ASTM B 88	Domestic Water Service and Distribution, Fire Protection, Solar, Fuel/Fule Oil, Natural Gas, Liquefied Petroleum (LP) Gas, HVAC, Snow Melting	STRAIGHT LENGTHS:
			1/4-inch to 10-inch 12-inch
			COILS:
			1/4-inch to 1-inch 1 1/4-inch and 1 1/2-inch 2-nch
TYPE M	ASTM B 88	Domestic Water Service and Distribution, Fire Protection, Solar, Fuel/Fule Oil, HVAC, Snow Melting	STRAIGHT LENGTHS: 1/4-inch to 12-inch
DWV	ASTM B 306	Drain, Waste, Vent, HVAC, Solar	STRAIGHT LENGTHS: 1 1/4-inch to 8-inch
ACR	ASTM B 280	Air Conditioning, Refrigeration, Natural Gas, Liquefied Petroleum (LP) Gas,	STRAIGHT LENGTHS:
			3/8-inch to 4-1/8 inch
			COILS:
			1/8-inch to 1-5/8 inch
OXY,MED, OXY/MED OXY/ACR, ACR/MED	ASTM B 819	Medical Gas	STRAIGHT LENGTHS: 1/4-inch to 8-inch

TABLE 2 Dimension and Physical Characteristics of Copper Tube : TYPE K

Nominal or Standard Size, inches	Nominal Dimensions, inches			Calculated Values (based on nominal dimensions)				
	Outside Diameter	Inside Diameter	Wall Thickness	Cross Sectional Area of Bore, sq inches	Weight of Tube Only, pounds per linear ft	Weight of Tube & Water, pounds per linear ft	Contents of Tube per linear ft	
							Cu ft	Gal
1/4	.375	.305	.035	.073	.145	.177	.00051	.00379
3/8	.500	.402	.049	.127	.269	.324	.00088	.00660
1/2	.625	.527	.049	.218	.344	.438	.00151	.0113
5/8	.750	.652	.049	.334	.418	.562	.00232	.0174
3/4	.875	.745	.065	.436	.641	.829	.00303	.0227
1	1.125	.995	.065	.778	.839	1.18	.00540	.0404
1 1/4	1.375	1.245	.065	1.22	1.04	1.57	.00847	.0634
1 1/2	1.625	1.481	.072	1.72	1.36	2.10	.0119	.0894
2	2.125	1.959	.083	3.01	2.06	3.36	.0209	.156
2 1/2	2.625	2.435	.095	4.66	2.93	4.94	.0324	.242
3	3.125	2.907	.109	6.64	4.00	6.87	.0461	.245
3 1/2	3.625	3.385	.120	9.00	5.12	9.01	.0625	.468
4	4.125	3.857	.134	11.7	6.51	11.6	.0813	.608
5	5.125	4.805	.160	18.1	9.67	17.5	.126	.940
6	6.125	5.741	.192	25.9	13.9	25.1	.180	1.35
8	8.125	7.583	.271	45.2	25.9	45.4	.314	2.35
10	10.125	9.449	.338	70.1	40.3	70.6	.487	3.64
12	12.125	11.315	.405	101	57.8	101	.701	5.25

TABLE 3 Dimension and Physical Characteristics of Copper Tube : TYPE L

Nominal or Standard Size, inches	Nominal Dimensions, inches			Calculated Values (based on nominal dimensions)				
	Outside Diameter	Inside Diameter	Wall Thickness	Cross Sectional Area of Bore, sq inches	Weight of Tube Only, pounds per linear ft	Weight of Tube & Water, pounds per linear ft	Contents of Tube per linear ft	
							Cu ft	Gal
1/4	.375	.315	.030	.078	.126	.160	.00054	.00405
3/8	.500	.430	.035	.145	.198	.261	.00101	.00753
1/2	.625	.545	.040	.233	.285	.386	.00162	.0121
5/8	.750	.666	.042	.348	.362	.512	.00242	.0181
3/4	.875	.785	.045	.484	.455	.664	.00336	.0251
1	1.125	1.025	.050	.825	.655	1.01	.00573	.0429
1 1/4	1.375	1.265	.055	1.26	.884	1.43	.00875	.0655
1 1/2	1.625	1.505	.060	1.78	1.14	1.91	.0124	.0925
2	2.125	1.985	.070	3.09	1.75	3.09	.0215	.161
2 1/2	2.625	2.465	.080	4.77	2.48	4.54	.0331	.248
3	3.125	2.945	.090	6.81	3.33	6.27	.0473	.354
3 1/2	3.625	3.425	.100	9.21	4.29	8.27	.0640	.478
4	4.125	3.905	.110	12.0	5.38	10.6	.0833	.623
5	5.125	4.875	.125	18.7	7.61	15.7	.130	.971
6	6.125	5.845	.140	26.8	10.2	21.8	.186	1.39
8	8.125	7.725	.200	46.9	19.3	39.6	.326	2.44
10	10.125	9.625	.250	72.8	30.1	61.6	.506	3.78
12	12.125	11.565	.280	105	40.4	85.8	.729	5.45

TABLE 4 Dimension and Physical Characteristics of Copper Tube : TYPE M

Nominal or Standard Size, inches	Nominal Dimensions, inches			Calculated Values (based on nominal dimensions)				
	Outside Diameter	Inside Diameter	Wall Thickness	Cross Sectional Area of Bore, sq inches	Weight of Tube Only, pounds per linear ft	Weight of Tube & Water, pounds per linear ft	Contents of Tube per linear ft	
							Cu ft	Gal
3/8	.500	.450	.025	.159	.145	.214	.00110	.00826
1/2	.625	.569	.028	.254	.204	.314	.00176	.0132
3/4	.875	.811	.032	.517	.328	.551	.00359	.0269
1	1.125	1.055	.035	.874	.465	.843	.00607	.0454
1 1/4	1.375	1.291	.042	1.31	.682	1.25	.00910	.0681
1 1/2	1.625	1.527	.049	1.83	.940	1.73	.0127	.0951
2	2.125	2.009	.058	3.17	1.46	2.83	.0220	.165
2 1/2	2.625	2.495	.065	4.89	2.03	4.14	.0340	.254
3	3.125	3.981	.072	6.98	2.68	5.70	.0485	.363
3 1/2	3.625	3.459	.083	9.40	3.58	7.64	.0653	.488
4	4.125	3.935	.095	12.2	4.66	9.83	.0847	.634
5	5.125	4.907	.109	18.9	6.66	14.8	.131	.982
6	6.125	5.881	.122	27.2	8.92	20.7	.189	1.41
8	8.125	7.785	.170	47.6	16.5	37.1	.331	2.47
10	10.125	9.701	.212	73.9	25.6	57.5	.513	3.84
12	12.125	11.617	.254	106	36.7	82.5	.736	5.51

TABLE 5 Dimension and Physical Characteristics of Copper Tube : DWV
(Drain, Waste and Vent)

Nominal or Standard Size, inches	Nominal Dimensions, inches			Calculated Values (based on nominal dimensions)				
	Outside Diameter	Inside Diameter	Wall Thickness	Cross Sectional Area of Bore, sq inches	Weight of Tube Only, pounds per linear ft	Weight of Tube & Water, pounds per linear ft	Contents of Tube per linear ft	
							Cu ft	Gal
1 ¹ / ₄	1.375	1.295	.040	1.32	.650	1.22	.00917	.0686
1 ¹ / ₂	1.625	1.541	.042	1.87	.809	1.62	.0130	.0971
2	2.125	2.041	.042	3.27	1.07	2.48	.0227	.170
3	3.125	3.035	.045	7.23	1.69	4.81	.0502	.376
4	4.125	4.009	.058	12.6	2.87	8.31	.0875	.655
5	5.125	4.981	.072	19.5	4.43	12.9	.135	1.01
6	6.125	5.959	.083	27.9	6.10	18.2	.194	1.45
8	8.125	7.907	.109	49.1	10.6	31.8	.341	2.55

TABLE 6 Dimension and Physical Characteristics of Copper Tube : ACR
(Air-Conditioning and Refrigeration Field Service) (A=Annealed Temper, D= Drawn Temper)

Nominal or Standard Size, inches		Nominal Dimensions, inches			Calculated Values (based on nominal dimensions)				
		Outside Diameter	Inside Diameter	Wall Thickness	Cross Sectional Area of Bore, sq inches	External Surface, sq ft per linear ft	Internal Surface, sq ft per linear ft	Weight of Tube Only, pounds per linear ft	Contents of Tube, cu ft per linear ft
1 ¹ / ₈	A	.125	.065	.030	.00332	.0327	.0170	.0347	.00002
3 ¹ / ₁₆	A	.187	.127	.030	.0127	.0490	.0332	.0575	.00009
1 ¹ / ₄	A	.250	.190	.030	.0284	.0654	.0497	.0804	.00020
5 ¹ / ₁₆	A	.312	.248	.032	.0483	.0817	.0649	.109	.00034
3 ¹ / ₈	A	.375	.311	.032	.076	.0982	.0814	.134	.00053
	D	.375	.315	.030	.078	.0982	.0825	.126	.00054
1 ¹ / ₂	A	.500	.436	.032	.149	.131	.114	.182	.00103
	D	.500	.430	.035	.145	.131	.113	.198	.00101
5 ¹ / ₈	A	.625	.555	.035	.242	.164	.145	.251	.00168
	D	.625	.545	.040	.233	.164	.143	.285	.00162
3 ¹ / ₄	A	.750	.680	.035	.363	.196	.178	.305	.00252
	D	.750	.666	.042	.348	.196	.174	.362	.00242
7 ¹ / ₈	A	.875	.785	.045	.484	.229	.206	.455	.00336
	D	.875	.785	.045	.484	.229	.206	.455	.00336
1 ¹ / ₈	A	1.125	1.025	.050	.825	.295	.268	.655	.00573
	D	1.125	1.025	.050	.825	.295	.268	.655	.00573
1 ³ / ₈	A	1.375	1.265	.055	1.26	.360	.331	.884	.00875
	D	1.375	1.265	.055	1.26	.360	.331	.884	.00875
1 ⁵ / ₈	A	1.625	1.505	.060	1.78	.425	.394	1.14	.0124
	D	1.625	1.505	.060	1.78	.425	.394	1.14	.0124
2 ¹ / ₈	D	2.125	1.985	.070	3.09	.556	.520	1.75	.0215
2 ⁵ / ₈	D	2.625	2.465	.080	4.77	.687	.645	2.48	.0331
3 ¹ / ₈	D	3.125	2.945	.090	6.81	.818	.771	3.33	.0473
3 ⁵ / ₈	D	3.625	3.425	.100	9.21	.949	.897	4.29	.0640
4 ¹ / ₈	D	4.125	3.905	.110	12.0	1.08	1.02	5.38	.0833

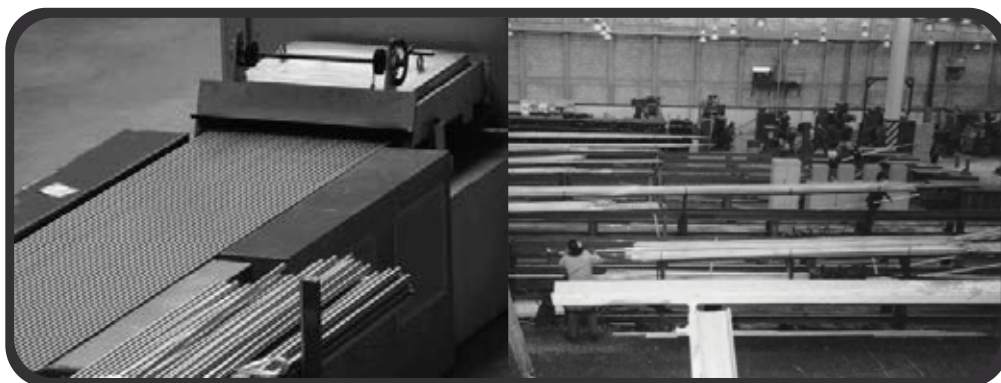

TABLE 7 Dimension and Physical Characteristics of Copper Tube : Medical Gas, K and L

Nominal or Standard Size, inches		Nominal Dimensions, inches			Calculated Values (based on nominal dimensions)			
		Outside Diameter	Inside Diameter	Wall Thickness	Cross Sectional Area of Bore, sq inches	Internal Surface, sq ft per linear ft	Weight of Tube Only, pounds per linear ft	Contents of Tube, cu ft per linear ft
1/4	K	.375	.305	.035	.073	.0789	.145	.00051
	L	.375	.315	.030	.078	.0825	.126	.00054
3/8	K	.500	.402	.049	.127	.105	.269	.00088
	L	.500	.430	.035	.145	.113	.198	.00101
1/2	K	.625	.527	.049	.218	.130	.344	.00151
	L	.625	.545	.040	.233	.143	.285	.00162
5/8	K	.750	.652	.049	.334	.171	.418	.00232
	L	.750	.666	.042	.348	.174	.362	.00242
3/4	K	.875	.745	.065	.436	.195	.641	.00303
	L	.875	.785	.045	.484	.206	.455	.00336
1	K	1.125	.995	.065	.778	.261	.839	.00540
	L	1.125	1.025	.050	.825	.268	.655	.00573
1 1/4	K	1.375	1.245	.065	1.222	.326	1.04	.00845
	L	1.375	1.265	.055	1.26	.331	.884	.00873
1 1/2	K	1.625	1.481	.072	1.72	.388	1.36	.0120
	L	1.625	1.505	.060	1.78	.394	1.14	.0124
2	K	2.125	1.959	.083	3.01	.522	2.06	.0209
	L	2.125	1.985	.070	3.09	.520	1.75	.0215
2 1/2	K	2.625	2.435	.095	4.66	.638	2.93	.0323
	L	2.625	2.465	.080	4.77	.645	2.48	.0331
3	K	3.125	2.907	.109	6.64	.761	4.00	.0461
	L	3.125	2.945	.090	6.81	.761	3.33	.0473
3 1/2	K	3.625	3.385	.120	9.00	.886	5.12	.0625
	L	3.625	3.425	.100	9.21	.897	4.29	.0640
4	K	4.125	3.857	.134	11.7	1.01	6.51	.0811
	L	4.125	3.905	.110	12.0	1.02	5.38	.0832
5	K	5.125	4.805	.160	18.1	1.26	9.67	.126
	L	5.125	4.875	.125	18.7	1.28	7.61	.130
6	K	6.125	5.741	.192	25.9	1.50	13.9	.180
	L	6.125	5.854	.140	26.8	1.53	10.2	.186
8	K	8.125	7.583	.271	45.2	1.99	25.9	.314
	L	8.125	7.725	.200	46.9	2.02	19.3	.325

TABLE 8 Rated Internal Working Pressure for Copper Tube : TYPE K

Nominal or Standard Size, inches	Annealed							Drawn						
	S= 6000 psi 100F	S= 5100 psi 150F	S= 4800 psi 200F	S= 4800 psi 250F	S= 4700 psi 300F	S= 4000 psi 350F	S= 3000 psi 400F	S= 9000 psi 100F	S= 9000 psi 150F	S= 9000 psi 200F	S= 9000 psi 250F	S= 8700 psi 300F	S= 8500 psi 350F	S= 8200 psi 400F
1/4	1074	913	860	860	842	716	537	1612	1612	1612	1612	1558	1522	1468
3/8	1130	960	904	904	885	753	565	1695	1695	1695	1695	1638	1601	1544
1/2	891	758	713	713	698	594	446	1337	1337	1337	1337	1293	1263	1218
5/8	736	626	589	589	577	491	368	1104	1104	1104	1104	1067	1043	1006
3/4	852	724	682	682	668	568	426	1278	1278	1278	1278	1236	1207	1165
1	655	557	524	524	513	437	327	982	982	982	982	949	928	895
1 1/4	532	452	425	425	416	354	266	797	797	797	797	771	753	727
1 1/2	494	420	396	396	387	330	247	472	472	472	472	472	717	700
2	435	370	348	348	341	290	217	652	652	652	652	630	616	594
1 1/2	398	338	319	319	312	265	199	597	597	597	597	577	564	544
3	385	328	308	308	302	257	193	578	578	578	578	559	546	527
3 1/2	366	311	293	293	286	244	183	549	549	549	549	530	518	500
4	360	306	288	288	282	240	180	540	540	540	540	522	510	492
5	345	293	276	276	270	230	172	517	517	517	517	500	488	471
6	346	295	277	277	271	231	173	520	520	520	520	502	491	474
8	369	314	295	295	289	246	184	553	553	553	553	535	523	504
10	369	314	295	295	289	246	184	553	553	555	553	535	523	504
12	370	314	296	296	290	247	185	555	555	555	555	536	524	506

TABLE 9 Rated Internal Working Pressure for Copper Tube : TYPE L

Nominal or Standard Size, inches	Annealed							Drawn						
	S=	S=	S=	S=	S=	S=	S=	S=	S=	S=	S=	S=	S=	
	6000 psi 100F	5100 psi 150F	4800 psi 200F	4800 psi 250F	4700 psi 300F	4000 psi 350F	3000 psi 400F	9000 psi 100F	9000 psi 150F	9000 psi 200F	9000 psi 250F	8700 psi 300F	8500 psi 350F	8200 psi 400F
1/4	912	775	729	729	714	608	456	1367	1367	1367	1367	1322	1292	1246
3/8	779	662	623	623	610	519	389	1168	1168	1168	1168	1129	1103	1064
1/2	722	613	577	577	565	481	361	1082	1082	1082	1082	1046	1022	986
5/8	631	537	505	505	495	421	316	947	947	947	947	916	895	863
3/4	582	495	466	466	456	388	291	873	873	873	873	844	825	796
1	494	420	395	395	387	330	247	741	741	741	741	717	700	676
1 1/4	439	373	351	351	344	293	219	658	658	658	658	636	622	600
1 1/2	408	347	327	327	320	272	204	613	613	613	613	592	579	558
2	364	309	291	291	285	242	182	545	545	545	545	527	515	497
2 1/2	336	285	269	269	263	224	168	504	504	504	504	487	476	459
3	317	270	254	254	248	211	159	476	476	476	476	460	449	433
3 1/2	304	258	243	243	238	202	152	455	455	455	455	440	430	415
4	293	249	235	235	230	196	147	440	440	440	440	425	415	401
5	269	229	215	215	211	179	135	404	404	404	404	390	381	368
6	251	213	201	201	196	167	125	376	376	376	376	364	355	343
8	270	230	216	216	212	180	135	406	406	406	406	392	383	370
10	271	231	217	217	212	181	136	407	407	407	407	393	384	371
12	253	215	203	203	199	169	127	380	380	380	380	368	359	346

TABLE 10 Rated Internal Working Pressure for Copper Tube : TYPE M

Nominal or Standard Size, inches	Annealed							Drawn						
	S=	S=	S=	S=	S=	S=	S=	S=	S=	S=	S=	S=	S=	
	6000 psi 100F	5100 psi 150F	4800 psi 200F	4800 psi 250F	4700 psi 300F	4000 psi 350F	3000 psi 400F	9000 psi 100F	9000 psi 150F	9000 psi 200F	9000 psi 250F	8700 psi 300F	8500 psi 350F	8200 psi 400F
1/4	-	-	-	-	-	-	-	-	-	-	-	-	-	-
3/8	570	485	456	456	447	380	285	855	855	855	855	827	808	779
1/2	494	420	395	395	387	329	247	741	741	741	741	716	700	675
5/8	-	-	-	-	-	-	-	-	-	-	-	-	-	-
3/4	407	346	326	326	319	271	204	611	611	611	611	590	577	556
1	337	286	270	270	264	225	169	506	506	506	506	489	477	461
1 1/4	338	287	271	271	265	225	169	507	507	507	507	490	479	462
1 1/2	331	282	265	265	259	221	166	497	497	497	497	480	469	453
2	299	254	239	239	234	199	149	448	448	448	448	433	423	408
2 1/2	274	233	219	219	215	183	137	411	411	411	411	397	388	375
3	253	215	203	203	199	169	127	380	380	380	380	367	359	346
3 1/2	252	214	202	202	197	168	126	378	378	378	378	366	357	345
4	251	213	201	201	197	167	126	377	377	377	377	364	356	343
5	233	198	186	186	182	155	116	349	349	349	349	338	330	318
6	218	186	175	175	171	146	109	328	328	328	328	317	310	299
8	229	195	183	183	180	153	115	344	344	344	344	332	325	313
10	230	195	184	184	180	153	115	344	344	344	344	333	325	314
12	230	195	184	184	180	153	115	345	345	345	345	333	326	314

TABLE 11 Rated Internal Working Pressure for Copper Tube : DWV

Nominal or Standard Size, inches	Annealed							Drawn						
	S=	S=	S=	S=	S=	S=	S=	S=	S=	S=	S=	S=	S=	
	6000 psi 100F	5100 psi 150F	4800 psi 200F	4800 psi 250F	4700 psi 300F	4000 psi 350F	3000 psi 400F	9000 psi 100F	9000 psi 150F	9000 psi 200F	9000 psi 250F	8700 psi 300F	8500 psi 350F	8200 psi 400F
1 1/8	330	280	264	264	258	220	165	494	494	494	494	478	467	451
1 1/2	293	249	235	235	230	196	147	440	440	440	440	425	415	401
2	217	185	174	174	170	145	109	326	326	326	326	315	308	297
3	159	135	127	127	125	106	80	239	239	239	239	231	225	217
4	150	127	120	120	117	100	75	225	225	225	225	217	212	205
5	151	129	121	121	119	101	76	227	227	227	227	219	214	207
6	148	126	119	119	116	99	74	223	223	223	223	215	210	203
8	146	124	117	117	114	97	73	219	219	219	219	212	207	200

TABLE 12 Rated Internal Working Pressure for Copper Tube : ACR (Air Conditioning and Refeigeration Tube Field Service)

Nominal or Standard Size, inches	Annealed							Drawn							
	COILS														
	S= 6000 psi 100F	S= 5100 psi 150F	S= 4800 psi 200F	S= 4800 psi 250F	S= 4700 psi 300F	S= 4000 psi 350F	S= 3000 psi 400F	S= 9000 psi 100F	S= 9000 psi 150F	S= 9000 psi 200F	S= 9000 psi 250F	S= 8700 psi 300F	S= 8500 psi 350F	S= 8200 psi 400F	
1/8	3074	2613	2459	2459	2408	2049	1537	-	-	-	-	-	-	-	
3/16	1935	1645	1548	1548	1516	1290	968	-	-	-	-	-	-	-	
1/4	1406	1195	1125	1125	1102	938	703	-	-	-	-	-	-	-	
5/16	1197	1017	957	957	937	798	598	-	-	-	-	-	-	-	
3/8	984	836	787	787	770	656	492	-	-	-	-	-	-	-	
1/2	727	618	581	581	569	485	363	-	-	-	-	-	-	-	
5/8	618	525	494	494	484	412	309	-	-	-	-	-	-	-	
3/4	511	435	409	409	400	341	256	-	-	-	-	-	-	-	
7/8	631	537	505	505	495	421	316	-	-	-	-	-	-	-	
1 1/8	582	495	466	466	456	388	291	-	-	-	-	-	-	-	
1 1/4	494	420	395	395	387	330	247	-	-	-	-	-	-	-	
1 1/2	439	373	351	351	344	293	219	-	-	-	-	-	-	-	
1 3/8	408	347	327	327	320	272	204	-	-	-	-	-	-	-	
	STRAIGHT LENGTHS														
	S= 6000 psi 100F	S= 5100 psi 150F	S= 4800 psi 200F	S= 4800 psi 250F	S= 4700 psi 300F	S= 4000 psi 350F	S= 3000 psi 400F	S= 9000 psi 100F	S= 9000 psi 150F	S= 9000 psi 200F	S= 9000 psi 250F	S= 8700 psi 300F	S= 8500 psi 350F	S= 8200 psi 400F	
3/8	912	775	729	729	714	608	456	1371	1371	1371	1371	1326	1295	1249	
1/2	779	662	623	623	610	519	389	1172	1172	1172	1172	1133	1107	1068	
5/8	722	613	577	577	565	481	361	1085	1085	1085	1085	1049	1025	989	
3/4	631	537	505	505	495	421	316	949	949	949	949	918	896	865	
7/8	582	495	466	466	456	388	291	875	875	875	875	846	827	797	
1 1/8	494	420	395	395	387	330	247	743	743	743	743	718	702	677	
1 1/4	439	373	351	351	344	293	219	660	660	660	660	638	623	601	
1 1/2	408	347	327	327	320	272	204	614	614	614	614	593	580	559	
2 1/8	364	309	291	291	285	242	182	546	546	546	546	528	516	498	
2 1/4	336	285	269	269	263	224	168	504	504	504	504	487	476	459	
3 1/8	317	270	254	254	248	211	159	476	476	476	476	460	449	433	
3 1/4	304	258	243	243	238	202	152	455	455	455	455	440	430	415	
4 1/8	293	249	235	235	230	196	147	440	440	440	440	425	415	401	

TABLE 13 Pressure Loss Due to Friction in Type M Copper Tube (pressure per 100 feet of tube, psi)

Flow, gpm	Nominal or Standard Size, Inches											
	3/8	1/2	3/4	1	1 1/4	1 1/2	2	2 1/2	3	4	5	6
1	2.5	0.8	0.2									
2	8.5	2.8	0.5	0.2								
3	17.3	5.7	1.0	0.3	0.1							
4	28.6	9.4	1.8	0.5	0.2							
5	42.2	13.8	2.6	0.7	0.3	0.1						
10		46.6	8.6	2.5	0.9	0.4	0.1					
15			17.6	5.0	1.9	0.9	0.2					
20			29.1	8.4	3.2	1.4	0.4	0.1				
25				12.3	4.7	2.1	0.6	0.2				
30				17.0	6.5	2.9	0.8	0.3	0.1			
35					8.5	3.8	1.0	0.4	0.2			
40					11.0	4.9	1.3	0.5	0.2			
45					13.6	6.1	1.6	0.6	0.2			
50						7.3	2.0	0.7	0.3			
60						1.2	2.7	1.0	0.4			
70						13.5	3.6	1.2	0.5	0.1		
80							4.6	1.6	0.7	0.2		
90							5.7	2.0	0.9	0.2		
100							7.5	2.7	1.0	0.3	0.1	
200								8.5	3.6	1.0	0.3	0.14
300									8.0	2.0	0.7	0.3
400										3.3	1.2	0.5
500											1.7	0.7
750											3.6	1.5
1000												2.5

NOTE : Number in bold face correspond to flow velocities of just over 10 feet per second.

Selecting the right tube for the job

Advantages of copper tube

High-strength, corrosion resistant, smooth-bore copper plumbing tube is the leading choice, by far, of modern contractors for plumbing and heating installations in all kinds of residential and commercial buildings. There are seven primary reasons for this popularity :

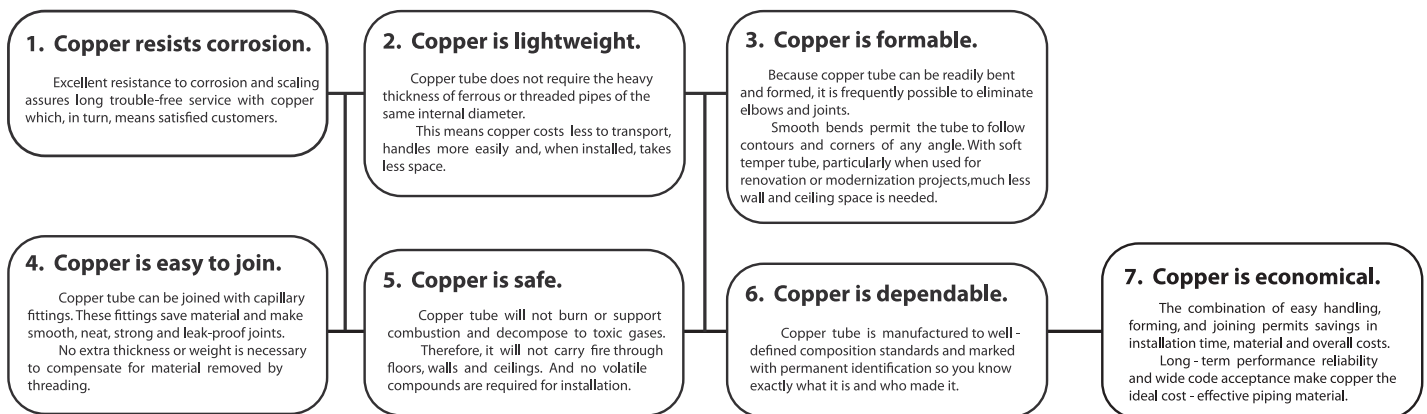

Recommendations for various applications

It is the designer's responsibility to determine the type of copper tube to be used in a particular application. Strength, formability, and other mechanical factors frequently determine the choice.

Sometimes building or plumbing codes govern what types may be used. When a choice can be made, it is helpful to know which type of copper tube has served and will serve successfully and economically in the following applications :

Underground Water Services—Use Type M for straight lengths joined with fittings, and Type L soft temper where coils are more convenient.

Water Distribution Systems—Use Type M for above and below ground.

Chilled Water Mains—Use Type M for sizes up to 1 inch and Type DWV for sizes of 1-1/4 inch and larger.

Drainage and Vent Systems—Use Type DWV for above and below ground, waste, soil, and vent lines, roof drainage, building drains, and building sewers.

Heating—For radiant panel and hydronic heating, and for snow melting systems, use Type L soft temper where the coils are formed in place or prefabricated, Type M where straight lengths joined with fittings are used. For hot-water heating and low-pressure steam, use Type M for sizes up to 1-1/4 inch and Type DWV for sizes of 1-1/4 inch and larger. For condensate return lines, Type L is successfully used.

Solar Heating—See "Heating" section above. For information on solar installation and on solar collectors, write CDA.

Fuel Oil and Underground Gas Services—Use copper tube in accord with local codes.

Oxygen Systems—Use Type L or K, suitably cleaned for oxygen service per NFPA* Publication No. 56F, "Non-flammable Medical Gas System."

