

ML7984 VALVE ACTUATOR

The ML7984 is a self-contained, self-adjusting, linear motorized linkage that mounts directly onto V5011 two-way or V5013 three-way valves and provides up to 19 mm (3/4") of linear travel (stem lift). For use with Series 70 2-10Vdc, 4-20mA electronic and Series 90 135 Ω , Electronic (Super Mod) modulating signal controllers.



- Allows the use of one common transformer power supply for multiple actuators and controllers
- Field-configurable DIP switches for Series 70 / 90 controller
- Field-configurable DIP switches for Direct / Reverse action
- Field-selectable terminals for 2-10Vdc / 4-20 mA signal input
- One device for either Vac or Vdc power supply application
- Compatible with 3 -wire system (one common wire for both signal & power inputs)
- Separate models available for V5011/13 A and C or V5011/13 F and G valve body types
- Self-contained, motorized valve linkage.
- Linkage self-adjusts to valve stroke of up to 19 mm (3/4")
- Multipoise mounting
- Strong valve seat closing force 710 Newton (160 lbs.)
- Compact size for easy installation in confined areas
- Electronic current sensing provides internal protection and positive full closing force
- Field-addable auxiliary switches available

CONTENTS

<i>Specifications</i>	2
<i>Order information</i>	2
<i>Installation</i>	3
<i>Wiring Schematics</i>	5
<i>Operation and Checkout</i>	12

Specifications

IMPORTANT:

The specifications given in this publication do not include normal manufacturing tolerances. Therefore, an individual unit may not exactly match the listed specifications. Also, this product is tested and calibrated under closely controlled conditions and some minor differences in performance can be expected if those conditions are changed.

Ambient Rating:

Operating Temperature:

0°C to 55°C (32°F to 130°F)

Shipping Temperature:

-40°C to +65°C (-40°F to 150°F)

Relative Humidity:

15% to 95% at 40°C (104°F)

Acoustic Noise:

55 dBA max. Sound Pressure Level at 1 m (39") distance.

Electrical Ratings:

Power supply/consumption:

24V (Nominal), 50/60Hz or

24 to 28 Vdc

6VA(Running), 12VA(Valve seating)

Input Impedance:

Voltage Model -- 20 K Ω

Current Model -- 237 Ω

Shipping Weight:

Approx. 1 kg (2.2 lbs)

Accessories/Parts:

272630A--Auxiliary switch assembly (1-SPDT)

272630B--Auxiliary switch assembly (2-SPDT)

272775--Replacement motor brush kit

40003793-003--Mounting hardware bag assembly

272822-- Resistor kit for multiple Series 90

application and for ML7984 to replace

the old ML784 (4-20 mA)

Mechanical Ratings:

Stroke--19mm (3/4") or less

Stroke timing-- Approx. 63 seconds for 3/4" stroke

Closing Force-- 710N (160 lbs.) Nominal*

*Rating applies to both directions.

Performance Specifications:

Life Expectancy-- (at rated load and power conditions)

50,000 full stroke cycles plus

1,000,000 repositions at 10% stem travel or 10 years, whichever occurs first.

Note: rapid repositioning will result in reduced service life of the actuator.

Ordering Information

When purchasing replacement and modernization products from your wholesaler or distributor, refer to the price sheets for complete ordering number, or specify--

1. Model number.
2. Valve body type and model number.
3. Accessories, if desired.

If you have additional questions, need further information, or would like to comment on our products or services, please write or phone:

1. Your local Honeywell Home and Building Control Sales office (check white pages of your phone directory).
2. Home and Building Control Customer Service Department

Honeywell Limited/Limitee

155 Gordon Baker Road

North York , Ontario

Canada M2H 3N7

In U.S.A. -- Honeywell Inc. 1985 Douglas Drive North, Minneapolis, Minnesota 55422-4386 (612) 951-1000

International Sales Offices in all principal cities of the world. Manufacturing in Australia, Canada, Finland, France, Germany, Japan, Mexico, Netherlands, Spain, United Kingdom, U.S.A.

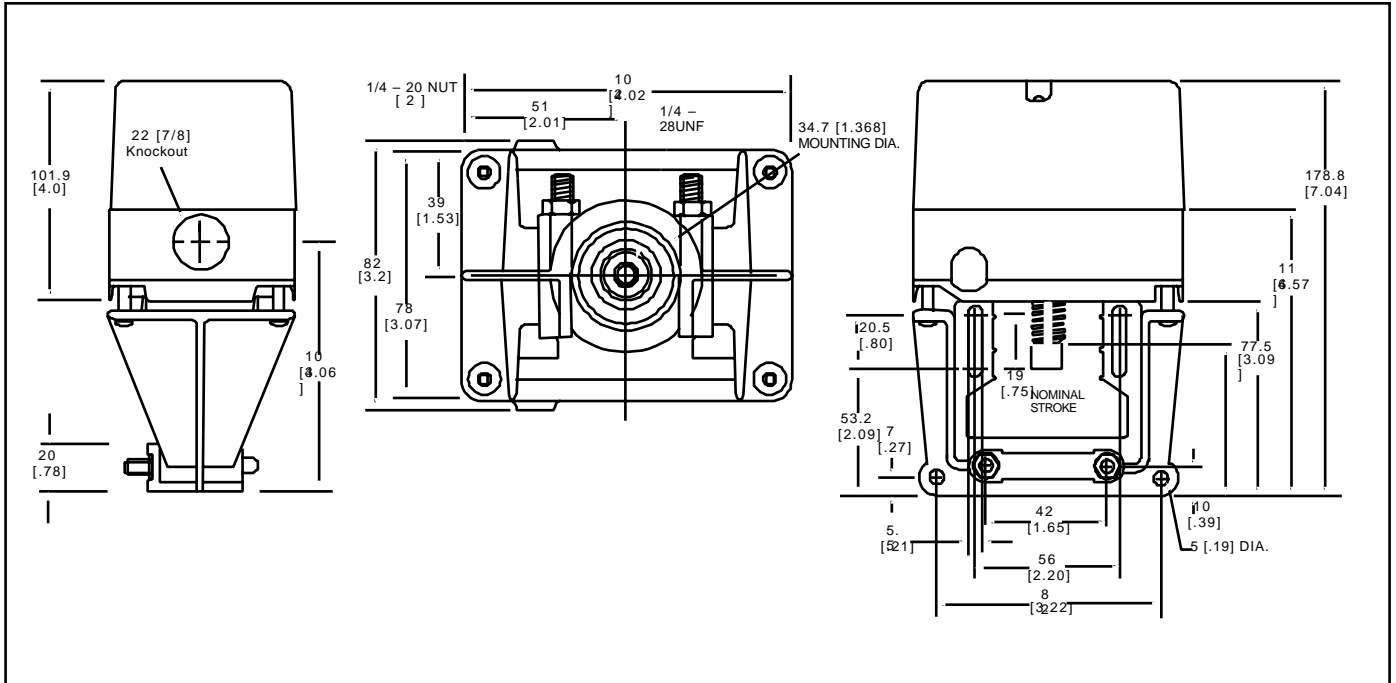

FIG. 1 -- DIMENSIONS OF ML7984 VALVE ACTUATOR IN MM (INCHES).

Installation

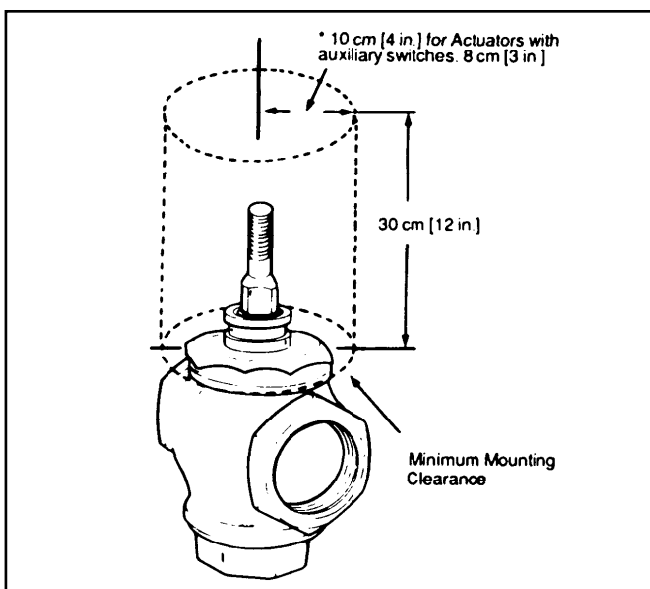

FIG.2 -- MINIMUM MOUNTING CLEARANCE.



CAUTION

1. Installer must be a trained service technician.
2. **DO NOT electrically operate the ML7984 before assembly to the valve because damage not apparent to the installer may occur.**

Mounting:

1. Ensure that the valve body is installed correctly, that is, the arrow points in the direction of the flow.
2. Although the actuator can be mounted in any position, it is preferable that the ML7984 is mounted above the valve body. This will minimize the risk of damage to the ML7984 in the event of condensation or a valve gland leak.
3. Remove the stem button (Fig. 3) from the valve stem. Save the set screw inside the stem button for later installation. The button itself is not needed.
4. Slide the position indicator (plastic disk or rubber O-ring) over the valve stem. (See inset, Fig. 3) Indicator will self-align to the marking on the yoke after one complete operating cycle.

Assembly of ML7984 to the valve:

1. The drive shaft of the ML7984 has a threaded hole to link with the valve stem. Slide the yoke over the valve bonnet (Fig. 4)
2. Thread the ML7984 drive shaft onto the valve stem **all the way**, until it is **completely attached (with no threads showing)**, by turning the valve actuator in a clockwise direction, as viewed from above (depending on the valve models, use a pin or wrench to keep valve stem from turning). Note that the valve actuator is shipped with drive shaft in the mid-position.

3. Care should be exercised when using the TOOLS on the valve stem during tightening. (Fig.4) DO NOT damage the threads or other parts of the stem.

4. Orient the conduit hole to the most desirable direction, then tighten the LOCKNUTS on the U-bolt.

INSTALLATION

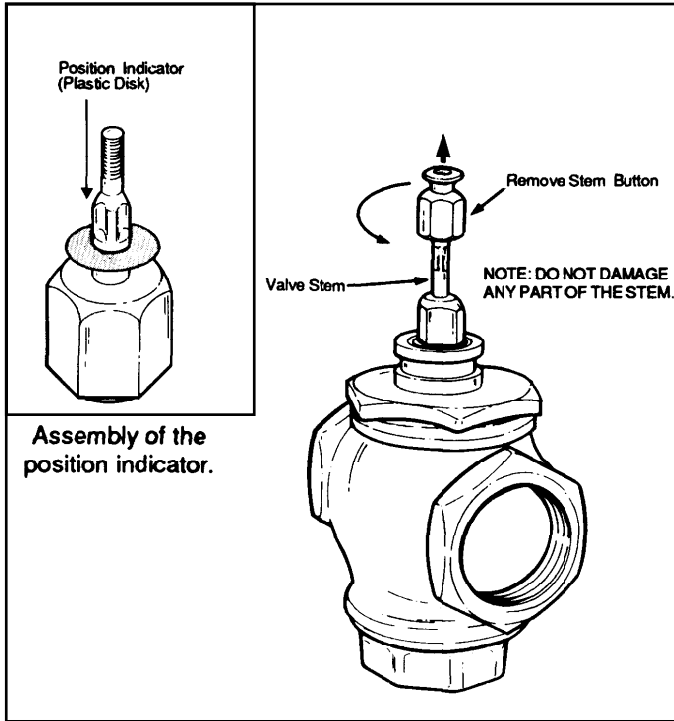

FIG.3 -- PREPARATION FOR VALVE ASSEMBLY.

5. Remove the plastic cover from the ML7984 by loosening the two screws located on the top (Note: These screws are captive. Rotate three complete revolutions to remove cover). Drop either Slot Headed or Allen Hex type of set screw (both are included in the plastic bag) into the top of the shaft, slotted/ Hexed side up. Or use the set screw from the valve stem button.

6. Depends on which type of set screw was used, with a 5 mm (3/16") Slotted screwdriver or 1/8"x 6" Allen wrench (included in the plastic bag), **tighten the set screw to lock valve stem in place** (Fig. 6).

! WARNING

For proper valve operation, valve stem must be **threaded into the actuator all the way (with no threads showing) and locked in place** with the set screw provided.

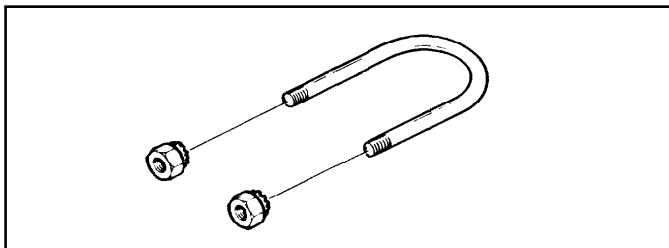

FIG. 5 -- U-BOLT ASSEMBLY.

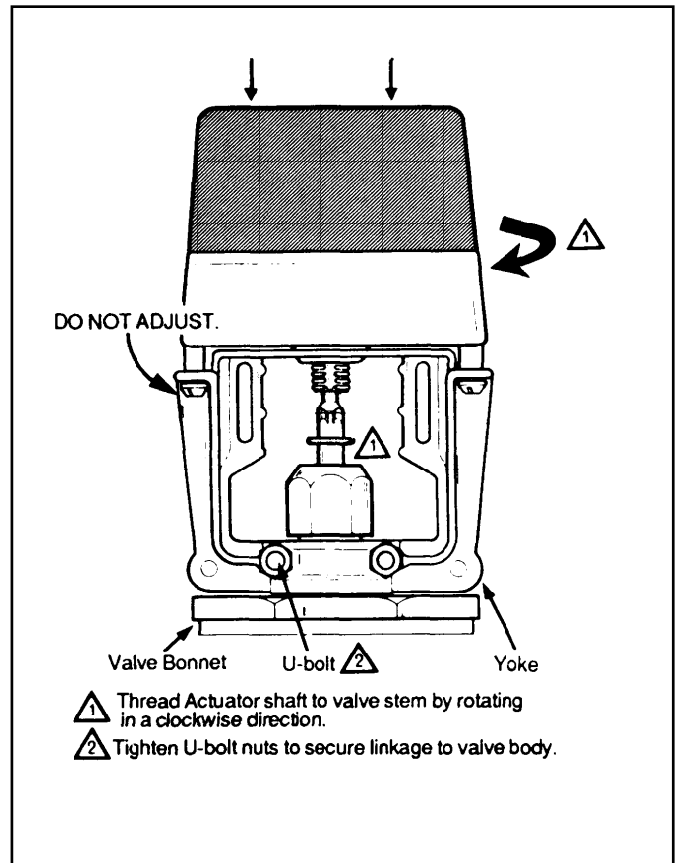

FIG. 4 -- ASSEMBLY OF ML7984A TO VALVE.

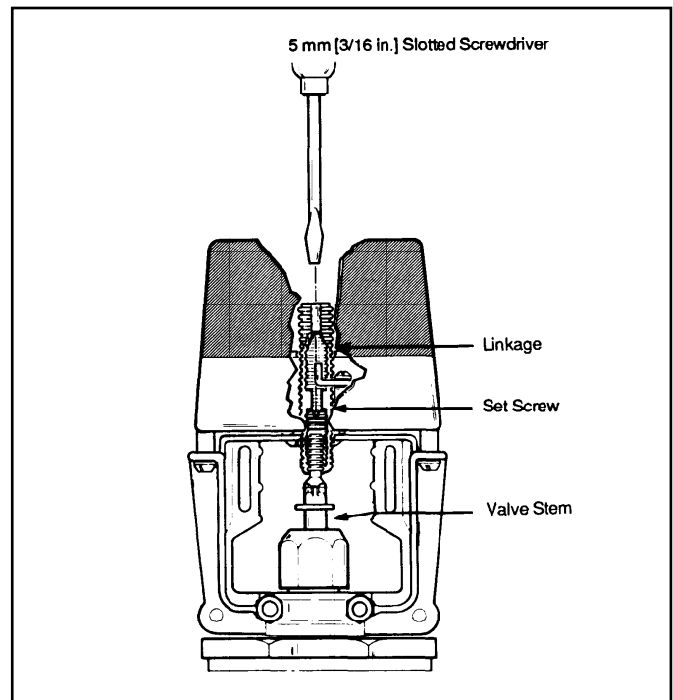
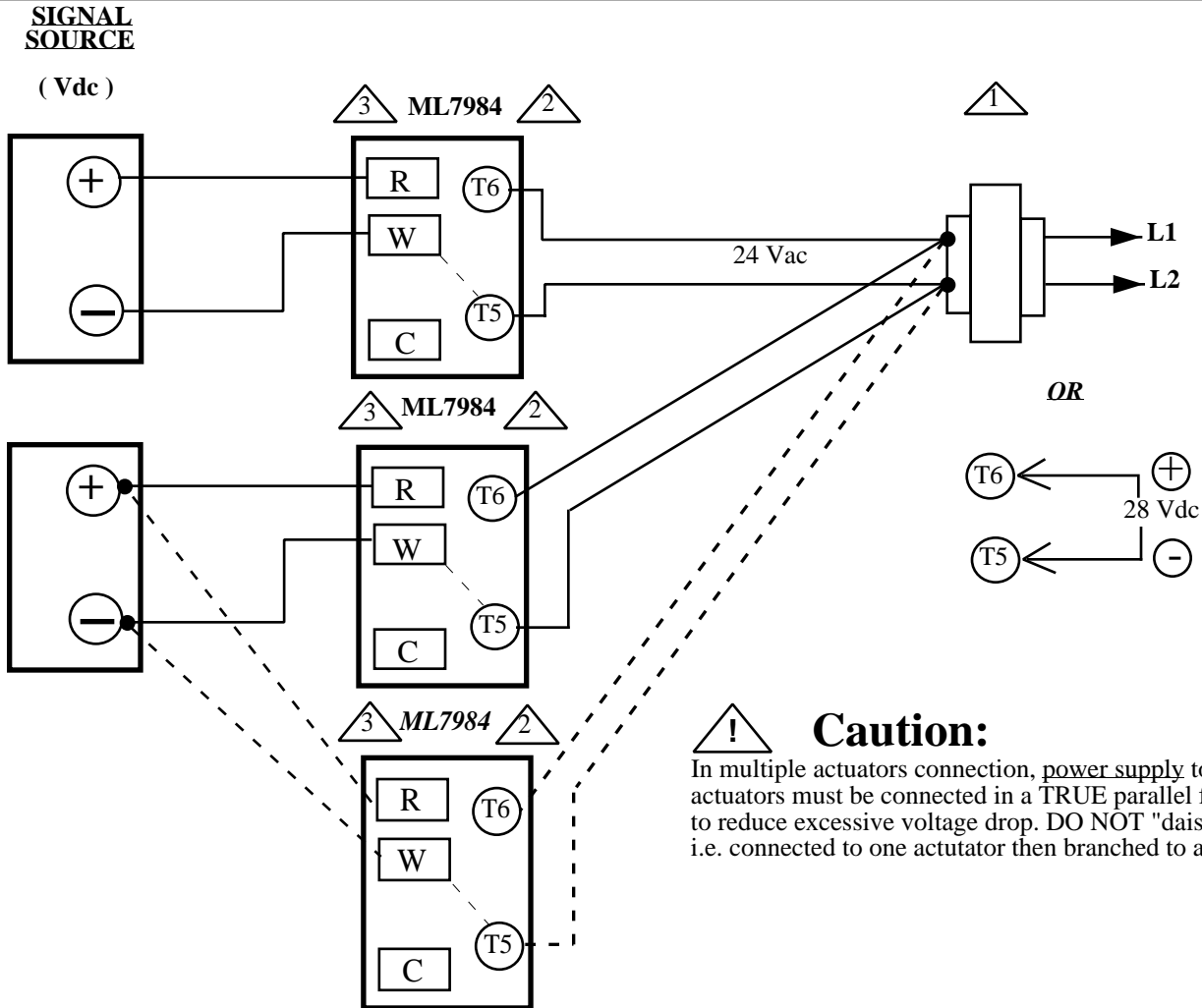

FIG. 6. -- LOCKING ML7984A DRIVE SHAFT TO VALVE STEM



- 1 Allow 0.5 amps maximum for each device. Actuators and controller can share same transformer providing the VA rating of the transformer is not exceeded and proper phasing is observed.
- 2 "T5" and "W" terminals are factory connected internally. Device is compatible with the 3-wire control system.
- 3 **Use configuration DIP switches to select device functions:** Direct acting function (actuator stem moves upwards with signal increases) or Reverse acting function (actuator stem moves downwards with signal increases).

Configuration DIP switches located adjacent to the input terminal block.

FUNCTION	DIP SWITCH CONFIGURATION										
2-10 Vdc Direct Acting	<table style="display: inline-table; border: none;"> <tr> <td><input type="checkbox"/></td> <td><input type="checkbox"/></td> <td><input type="checkbox"/></td> <td><input type="checkbox"/></td> <td>on</td> </tr> <tr> <td>1</td> <td>2</td> <td>3</td> <td>4</td> <td>off</td> </tr> </table>	<input type="checkbox"/>	<input type="checkbox"/>	<input type="checkbox"/>	<input type="checkbox"/>	on	1	2	3	4	off
<input type="checkbox"/>	<input type="checkbox"/>	<input type="checkbox"/>	<input type="checkbox"/>	on							
1	2	3	4	off							
10-2 Vdc Reverse Acting	<table style="display: inline-table; border: none;"> <tr> <td><input type="checkbox"/></td> <td><input type="checkbox"/></td> <td><input type="checkbox"/></td> <td><input type="checkbox"/></td> <td>on</td> </tr> <tr> <td>1</td> <td>2</td> <td>3</td> <td>4</td> <td>off</td> </tr> </table>	<input type="checkbox"/>	<input type="checkbox"/>	<input type="checkbox"/>	<input type="checkbox"/>	on	1	2	3	4	off
<input type="checkbox"/>	<input type="checkbox"/>	<input type="checkbox"/>	<input type="checkbox"/>	on							
1	2	3	4	off							

NOTE:
Turn power off before setting the DIP switches.

Fig. 7 Wiring for Series 70 (Vdc) signal input ML7984 actuators

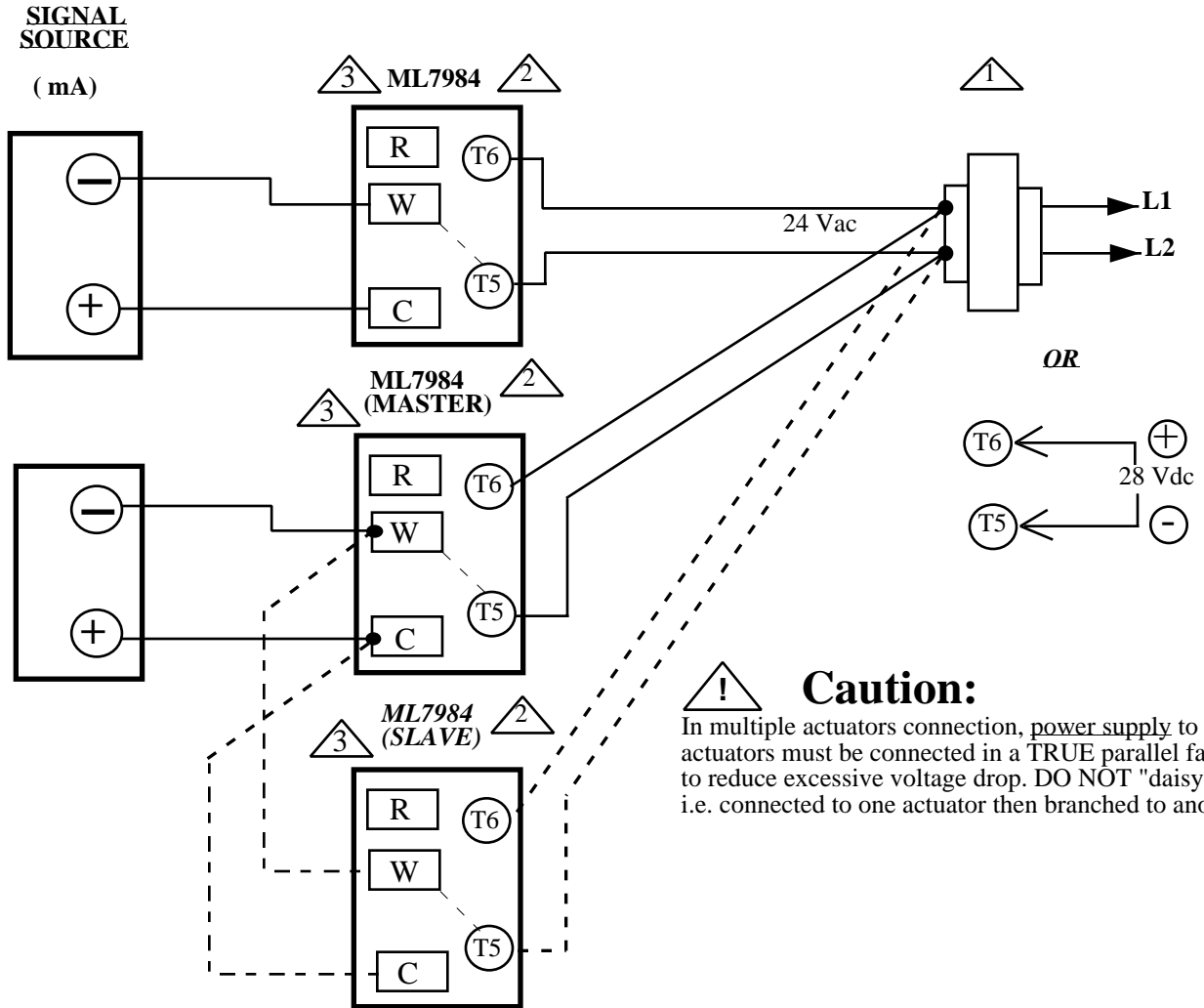

Caution:
In multiple actuators connection, power supply to all actuators must be connected in a TRUE parallel fashion to reduce excessive voltage drop. DO NOT "daisy chain" i.e. connected to one actuator then branched to another.

- 1 Allow 0.5 amps maximum for each device. Actuators and controller can share same transformer providing the VA rating of the transformer is not exceeded and proper phasing is observed.
- 2 "T5" and "W" terminals are factory connected internally. Device is compatible with the 3-wire control system.
- 3 **Use configuration DIP switches to select device functions:** Direct acting function (actuator stem moves upwards with signal increases) or Reverse acting function (actuator stem moves downwards with signal increases).

Configuration DIP switches located adjacent to the input terminal block.

FUNCTION	DIP SWITCH CONFIGURATION
4-20 mA Direct Acting	<div style="display: flex; align-items: center;"> <div style="margin-right: 10px;"> <input type="checkbox"/> Master actuator <input type="checkbox"/> Slave actuator </div> <div style="display: flex; gap: 10px;"> <div style="text-align: center;"> <input type="checkbox"/> 1 </div> <div style="text-align: center;"> <input type="checkbox"/> 2 </div> <div style="text-align: center;"> <input type="checkbox"/> 3 </div> <div style="text-align: center;"> <input type="checkbox"/> 4 </div> </div> <div style="margin-left: 10px; text-align: right;"> on off </div> </div>
20-4 mA Reverse Acting	<div style="display: flex; align-items: center;"> <div style="margin-right: 10px;"> <input type="checkbox"/> Master actuator <input type="checkbox"/> Slave actuator </div> <div style="display: flex; gap: 10px;"> <div style="text-align: center;"> <input type="checkbox"/> 1 </div> <div style="text-align: center;"> <input type="checkbox"/> 2 </div> <div style="text-align: center;"> <input type="checkbox"/> 3 </div> <div style="text-align: center;"> <input type="checkbox"/> 4 </div> </div> <div style="margin-left: 10px; text-align: right;"> on off </div> </div>

NOTE:
Turn power off before setting the DIP switches.

Fig. 8 Wiring for Series 70 (mA) signal input ML7984 actuators

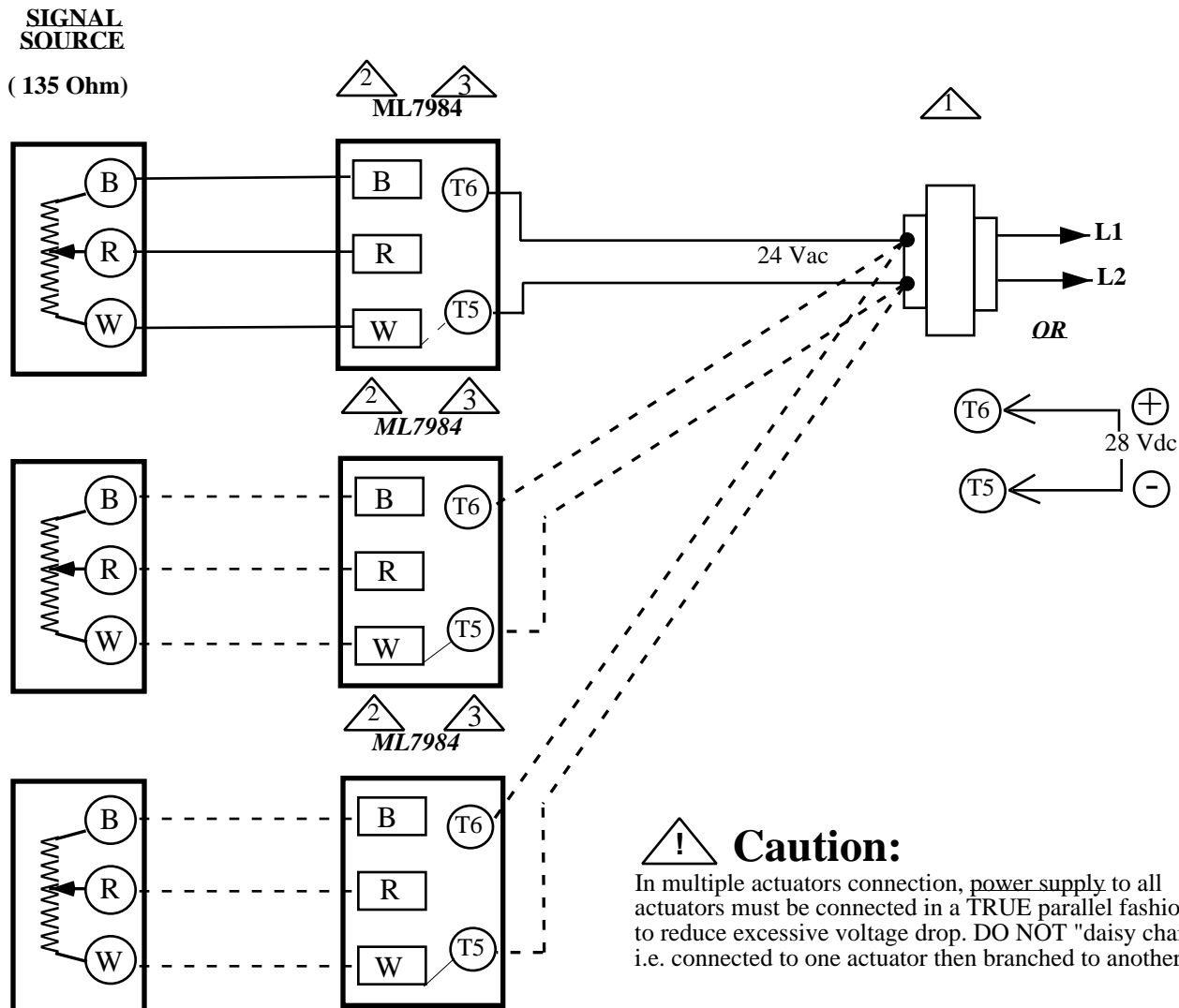

- ① Allow 0.5 amps maximum for each device.
 - ② Do not mix M984/6 or Modutrol Motors with the ML7984 in the same circuitry.
 - ③ Use **configuration DIP switches to select device functions:** Direct acting function (actuator stem moves upwards with signal increases) or Reverse acting function (actuator stem moves downwards with signal increases).
- * Series 90 (mech/electronic) operation can be reversed without changing wiring by using DIP switch #3 (opposite as shown).

Configuration DIP switches located adjacent to the input terminal block

FUNCTION	DIP SWITCH CONFIGURATION
* Series 90 (Mechanical 135 Ω) i.e. T991	<div style="display: flex; align-items: center; gap: 10px;"> <div style="border: 1px solid black; width: 15px; height: 15px; margin-bottom: 2px;"></div> 1 <div style="border: 1px solid black; width: 15px; height: 15px; margin-bottom: 2px;"></div> 2 <div style="border: 1px solid black; width: 15px; height: 15px; margin-bottom: 2px;"></div> 3 <div style="border: 1px solid black; width: 15px; height: 15px; margin-bottom: 2px;"></div> 4 <div style="margin-left: 10px;">on off</div> </div>

- NOTE:**
- 1.) Turn power off before setting the DIP switches.
 - 2.) For common transformer + common controller application, please consult the factory

Fig. 9A Wiring for multiple Series 90 (135 Ohm Slide Wire) signal inputs ML7984 actuators

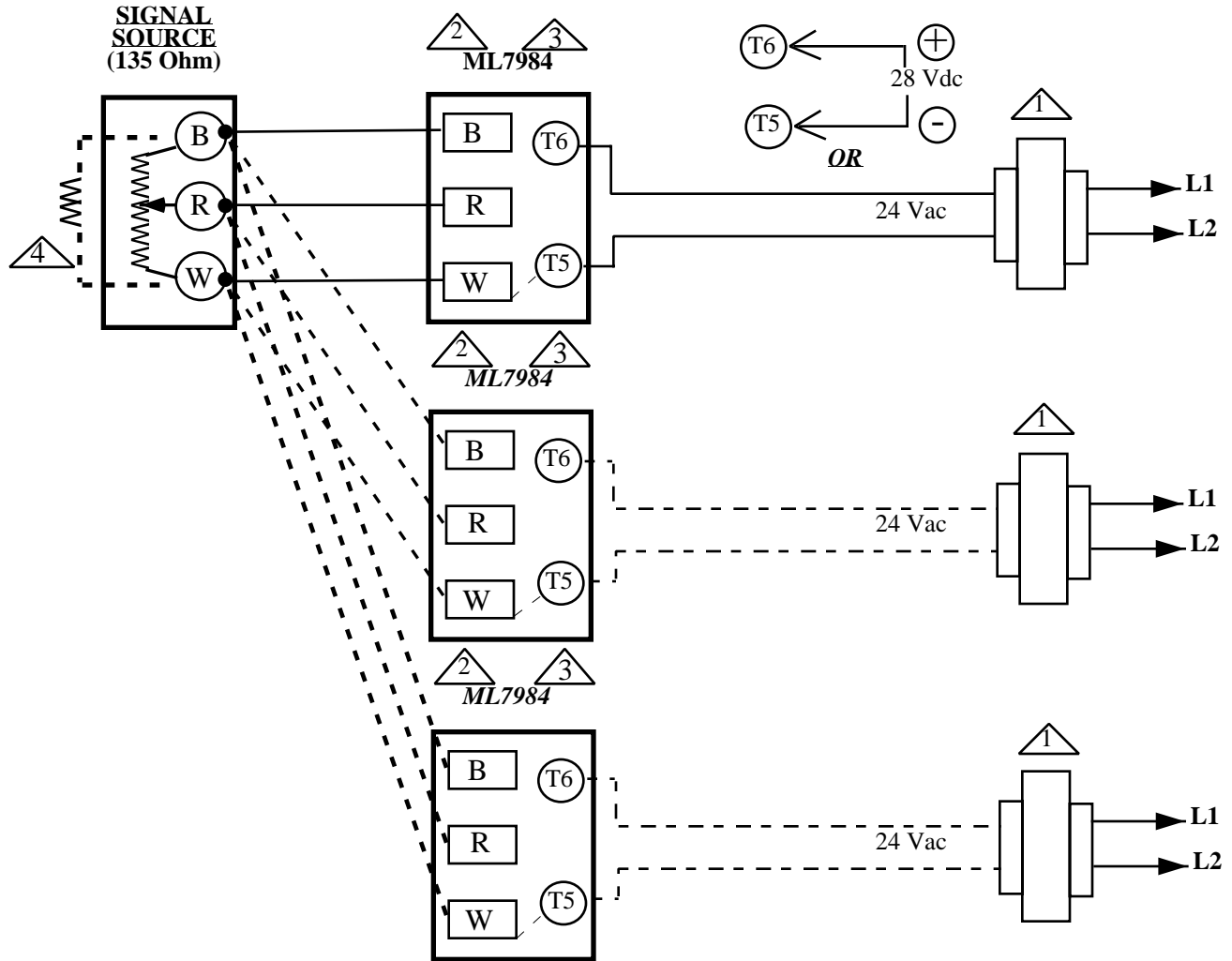

- 1 Allow 0.5 amps maximum for each device.
- 2 Do not mix M984/6 or Modutrol Motors with the ML7984 in the same circuitry.
- 3 **Use configuration DIP switches to select device functions:** Direct acting function (actuator stem moves upwards with signal increases) or Reverse acting function (actuator stem moves downwards with signal increases).
- 4 Use Resistor Kit part # 272822

RESISTOR SELECTION CHART		
NO. OF ACTUATORS	RESISTOR VALUE	
1	RESISTOR NOT REQ'D.	ALL RESISTORS 1/4WATT 1% M.F.
2	133 OHM	
3	68.1 OHM	
4	45.3 OHM	

* Series 90 (mech/electronic) operation can be reversed without changing wiring by using DIP switch #3 (opposite as shown).

Configuration DIP switches located adjacent to the input terminal block.

FUNCTION	DIP SWITCH CONFIGURATION
* Series 90 (Mechanical 135 Ω) i.e. T991	<input type="checkbox"/> 1 <input type="checkbox"/> 2 <input type="checkbox"/> 3 <input type="checkbox"/> 4 on <input type="checkbox"/> 1 <input type="checkbox"/> 2 <input type="checkbox"/> 3 <input type="checkbox"/> 4 off

NOTE: 1.) Turn power off before setting the DIP switches.
2.) For common transformer + common controller application, please consult the factory

Fig. 9B Wiring for Single Series 90 (135 Ohm Slide Wire) signal input ML7984 actuators

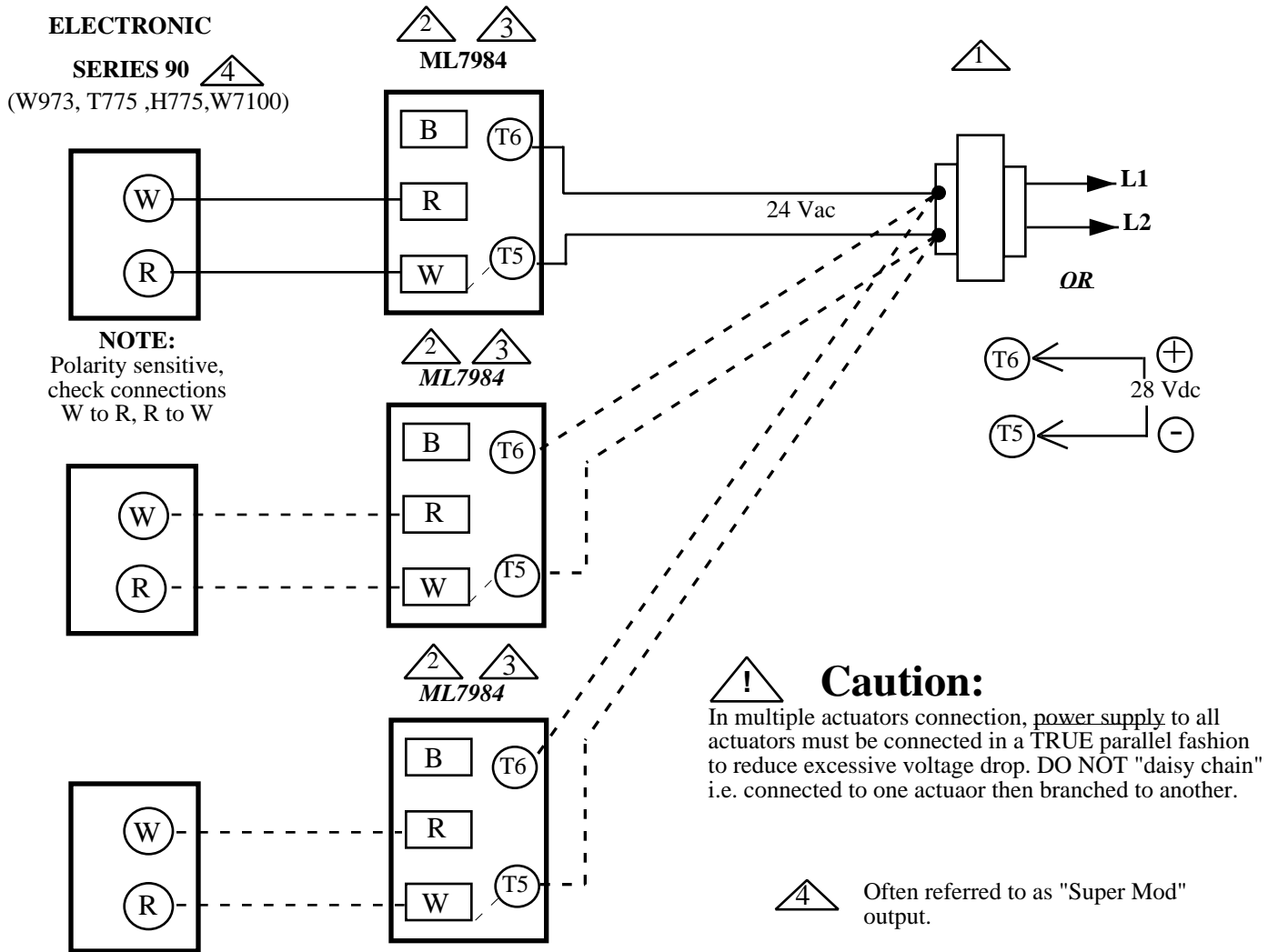

- 1 Allow 0.5 amps maximum for each device.
 - 2 Do not mix M984/6 or Modutrol Motors with the ML7984 in the same circuitry.
 - 3 **Use configuration DIP switches to select device functions:** Direct acting function (actuator stem moves upwards with signal increases) or Reverse acting function (actuator stem moves downwards with signal increases).
- * Series 90 (mech/electronic) operation can be reversed without changing wiring by using DIP switch #3 (opposite as shown).

Configuration DIP switches located adjacent to the input terminal block

FUNCTION	DIP SWITCH CONFIGURATION
* Series 90 (Electronic Super Mod) i.e. T775	<div style="display: flex; justify-content: space-around; align-items: center;"> <div style="text-align: center;"> <input type="checkbox"/> 1 on off </div> <div style="text-align: center;"> <input type="checkbox"/> 2 on off </div> <div style="text-align: center;"> <input type="checkbox"/> 3 on off </div> <div style="text-align: center;"> <input type="checkbox"/> 4 on off </div> </div>

- NOTE:**
- 1.) Turn power off before setting the DIP switches.
 - 2.) For common transformer + common controller application, please consult the factory

Fig. 10A Wiring for multiple Series 90 (Electronic Super Mod) signal inputs ML7984 actuators



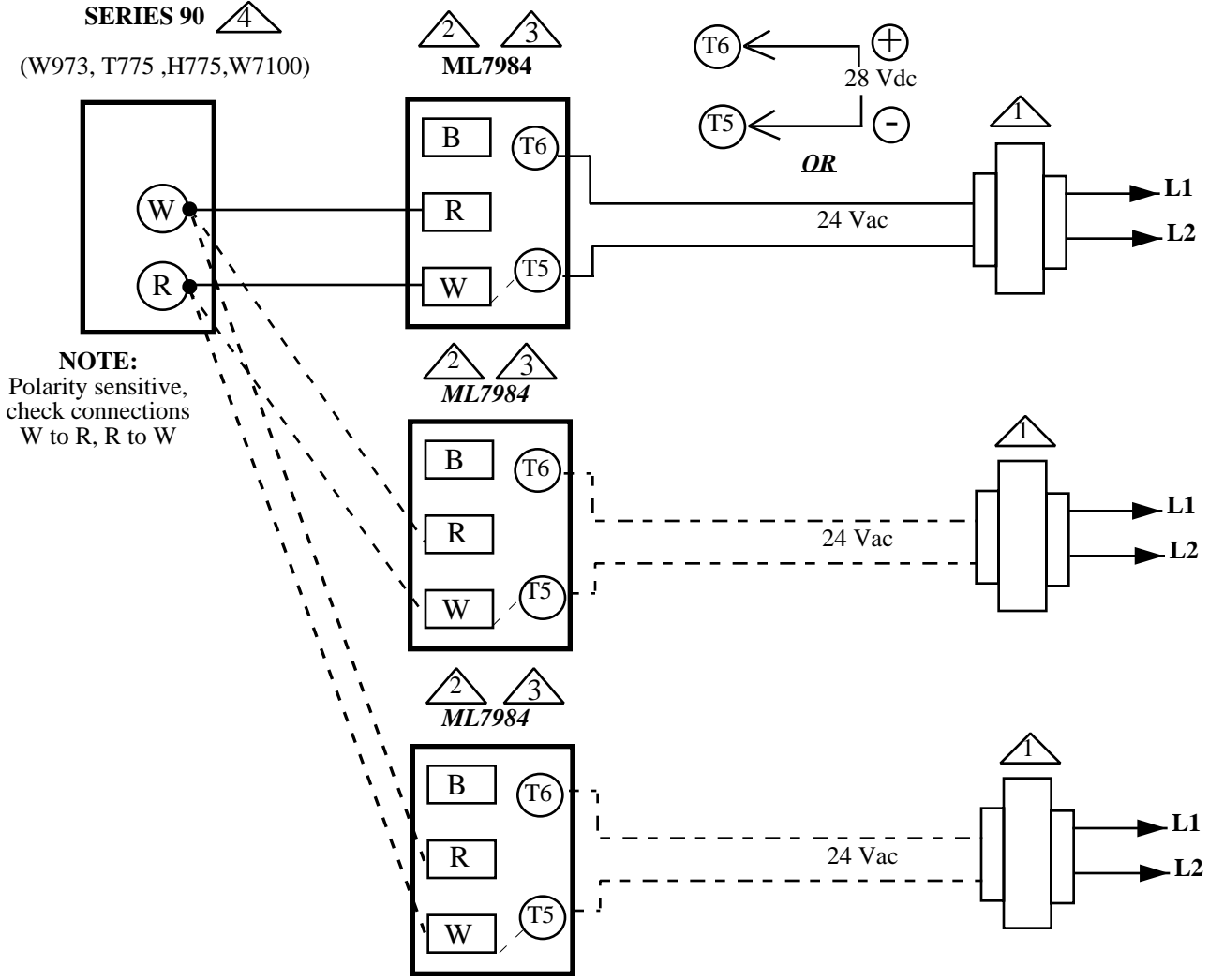

ELECTRONIC

SERIES 90 

(W973, T775, H775, W7100)



NOTE:
Polarity sensitive,
check connections
W to R, R to W

-  Allow 0.5 amps maximum for each device.
-  Do not mix M984/6 or Modutrol Motors with the ML7984 in the same circuitry.
-  Use **configuration DIP switches to select device functions:** Direct acting function (actuator stem moves upwards with signal increases) or Reverse acting function (actuator stem moves downwards with signal increases).
-  Often referred to as "Super Mod" output.

* Series 90 (mech/electronic) operation can be reversed without changing wiring by using DIP switch #3 (opposite as shown).

**Configuration
DIP switches
located adjacent
to the input
terminal block**

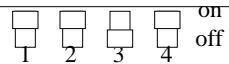
FUNCTION	DIP SWITCH CONFIGURATION
* Series 90 (Electronic Super Mod) i.e. T775	

NOTE: 1.) Turn power off before setting the DIP switches.
2.) For common transformer + common controller application, please consult the factory

Fig. 10B Wiring for single Series 90 (Electronic Super Mod) signal input ML7984 actuators

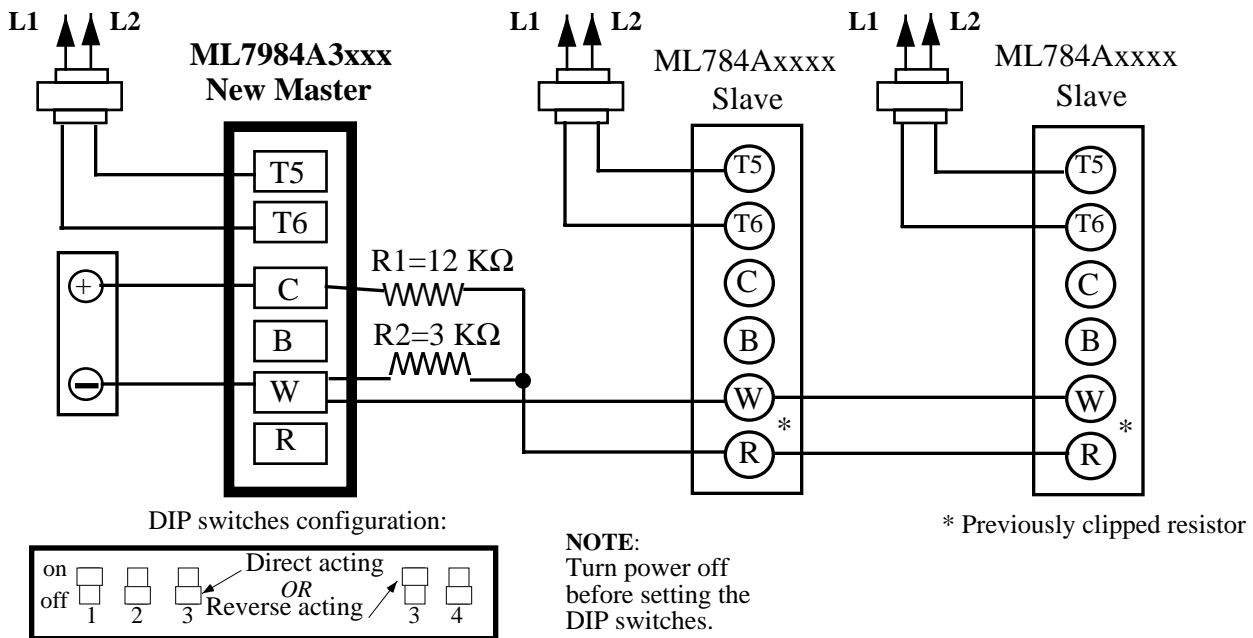

Fig. 11 Wiring for replacing the MASTER motor in 4-20 mA multiple-actuator application. (use Resistor Kit part # 272822)

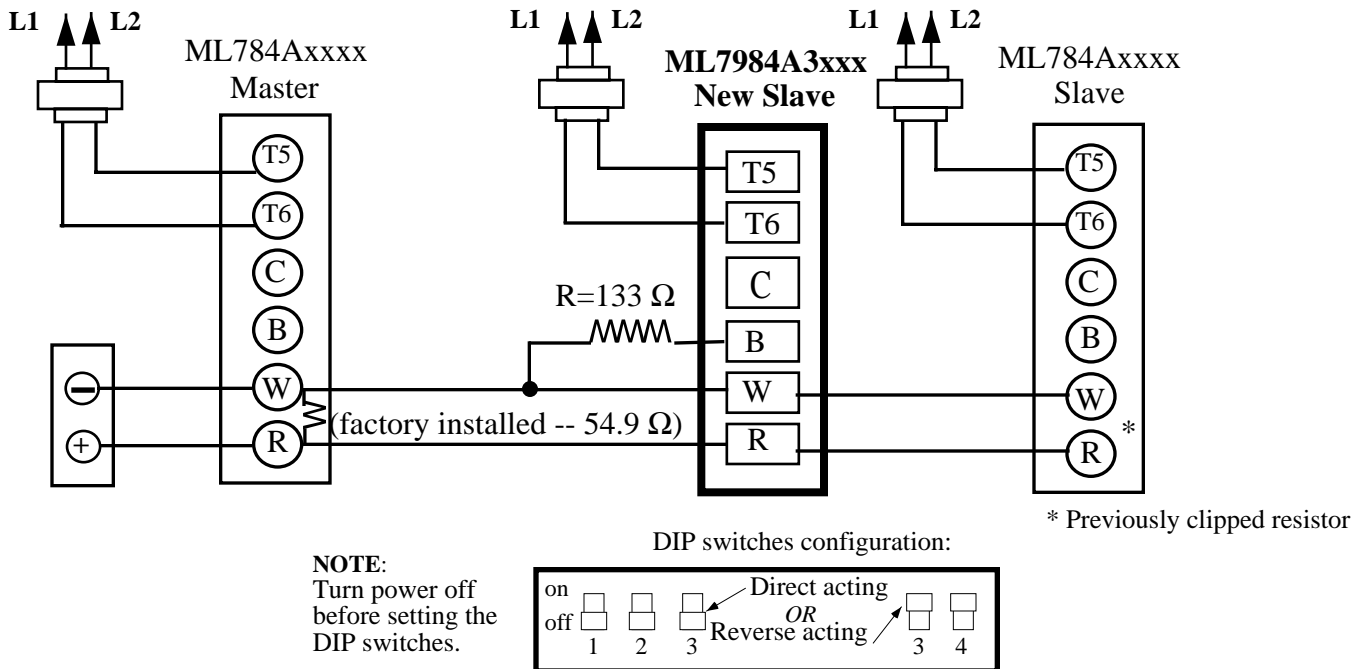

Fig. 12 Wiring for replacing the SLAVE motor in 4-20 mA multiple-actuator application. (use Resistor Kit part # 272822)

Operation and checkout

Operation:

The recommended valve actuator power source is a class 2, 24V transformer or 28Vdc across terminals T5 & T6 (See Fig.7-10). The internal circuitry provides dc power for the electronic sensing and drive motor circuits. The sensing circuits respond to the signal across the input terminals based on the configuration DIP switches setting.

When correctly connected to the actuator, control signal between signal input terminals is compared to similar voltage across the actuator feedback potentiometer. When these voltages are equal, the drive motor and drive shaft are stationary.

As long as the value of controlled medium remains at the controller setpoint, the circuit is in balance, and the actuator does not run. When the value of the controlled medium changes, the controller output voltage is changed causing reference voltages in the circuit to be out of balance. As the actuator moves in the direction to correct the medium change, the feedback potentiometer also moves to rebalance the circuit, and stop the actuator.

At the end of the valve stroke, the actuator continues to drive and gradually develops the necessary force for positive valve close-off. The actuator motor stops automatically when the motor current reaches the predetermined current & force level.



CAUTION:

1. Disconnect power supply before beginning installation to prevent electrical shock and equipment damage.
2. All wiring must comply with applicable local electrical codes, ordinances and regulations.
3. Make certain that the voltage and frequency of the power supply correspond to the rating of the device.
4. DO NOT connect 24 Vac between any signal input terminals. DEVICE FAILURE WILL RESULT!
5. **DO NOT electrically operate the ML7984 before assembly to the valve because damage not apparent to the installer may occur.**

GENERAL NOTE:

1. For correct valve operation, the ML7984 must be **field configured** with the DIP switches which are located beside the terminal block, see wiring diagrams for details. **Turn power off before setting the DIP switches .**
2. There is a short delay in actuator response upon every signal change. It is to screen any unwanted incoming signals.
3. For proper operation, voltage on the T5 & T6 **must not be less than** 22Vac or 24Vdc during running or force generating stages.

REPLACEMENT NOTE:

1. The **old** ML784 or ML984 actuators cannot be used with **new** ML7984 valve actuators in the same circuitry, unless they (the old ones) are each isolated by its own transformer to prevent cross-talking.
2. The ML7984 is a direct replacement for all the old ML784 and ML984, except:
 - a.) when replacing the old reverse acting models, the signal input wires to the new devices are no longer needed to be reversed. Just follow the terminal polarity designations.
 - b.) when replacing the old actuator which has an Electronic Series 90 controller, i.e., T775, W973, H775, W7100, the old interface resistor must be removed. The new ML7984 will work directly with the controller without that external 240Ω resistor.
 - c.) when replacing the old ML784 (mA model) in multiple-actuator installations, resistor(s) will be needed. Use Resistor Kit part # 272822 and set DIP switches accordingly. See Figure 11 & 12.

Checkout:(see General & Replacement Note)

1. Make sure the valve stem is completely screwed into the actuator drive shaft with no threads showing.
2. Make sure the valve stem is locked in place with the set screw.
3. Make sure the Configuration DIP switches are set correctly.
4. With 24Vac or 28Vdc power source connected to T5 & T6, actuator operation can be verified by connecting appropriate control signal (Series 70/90) from controller to the signal input terminals (Fig. 7-10).
 For direct acting: A modulating action can be obtained simply by increasing the control signal. The actuator will travel from a fully closed position (Stem down) to a fully open position (Stem up). On signal failure (disconnected / no signal), actuator defaults to closed position.
 For reverse acting: Decreasing controller signal will drive actuator from fully closed (Stem down) to a fully open position (Stem up). On signal failure (disconnect/no signal), actuator defaults to open position.
5. Operate the system (valve, actuator and controller) for several cycles to ensure proper installation.
6. When checkout is completed, return the controller to the desired setting.

NOTE: Device will ignore any input changes until it has completed its repositioning relative to the initial signal input.