

AV-D-10 and AV-R-10

AIR VELOCITY TRANSMITTERS

PRODUCT DATA



GENERAL

The AV-D-10 Duct-Mounted and AV-R-10 Remote Air Velocity Transmitters are designed for highly accurate measurement of air velocity up to 20 m/s (2000 ft/min). They feature a thin-film sensor which operates according to the hot-film anemometer principle. The mounting flange permits a continuous adjustment of immersion depth at the duct. The output signal, measuring range, and response time can be adjusted by shifting a jumper on the circuit board. These air velocity transmitters are suitable for use in all systems capable of accepting 0...10 VDC inputs and are ideal for accurate and reliable measurement in building automation and ventilation applications. For special applications, please contact Honeywell.

ACCURACY

The anemometer is temperature-compensated. The measurement principle establishes a relationship between the flow and the heat capacity of air. Thus, at lower air pressure, the actual flow speed is higher than the indicated flow speed. This is expressed by the following equation:

$$V_{\text{actual}} = V_{\text{indicated}} * 1013 \text{ mbar} / \text{Pressure}_{\text{real}} \text{ (in mbar)}$$

MOUNTING

NOTE: The accurate and reliable determination of air velocity depends on the correct positioning of the probe. Accurate measurements are possible only if the probe is installed in a location with low-turbulence flow. Extreme mechanical and unspecified strain and corrosive environments and condensation must be avoided. See also AV-R-10 and AV-D-10 – Mounting Instructions (MU1B-0620GE51).

FEATURES

- Highly accurate measurement of air velocities of up to 20 m/s (2000 ft/min).
- Mounting flange permits continuous adjustment of immersion depth at duct.
- Response time (t_{90}), measuring range, and output signal (0...10 V / 4...20 mA) can all be independently reset by shifting jumpers on the circuit board.
- Self-compensation for changes in air temperature.

SPECIFICATION

Measuring range

Working range 2...10 m/s (6...2000 ft/min)
2...15 m/s (6...3000 ft/min)
2...20 m/s (6...4000 ft/min)

Accuracy $\pm(0.2 \text{ m/s} + 3\% \text{ of m.v.})$ at
20 °C (68 °F), 45% r.H.,
1013 hPa

Response time T_{90} typ. 4 s (default) or
1 s (constant temperature)

General

Power supply 24 VAC/DC $\pm 20\%$ (SELV)
Output 0...10 V, 4...20 mA (default);
-1 mA $< I_L < 1$ mA
 $R_L < 500 \Omega$ (linear, 3 wires)

Current consumption max. 170 mA (AC),
max. 70 mA (DC)

Electrical connection screw terminals, max. 1.5 mm²
(AWG 16)

Cable gland M16x1.5

Approvals CE

Housing material Polycarbonate, UL94V-0
approved

Protection class Enclosure IP65 / NEMA 4,
remote probe IP20

Storage temperature -30...+60 °C (-22...+140 °F)

Working temp. probe -25...+50 °C (-13...+122 °F)

Working temp. electronics -10...+50 °C (+14...+122 °F)

Working humidity 5...95% r.H. (non-condensing)

Dimensions

see Fig. 1 on page 2

MODELS

Order no.	Cable length	Immersion depth
AV-D-10	--	50...200 mm
AV-R-10	1 meter	50...300 mm

DIMENSIONS

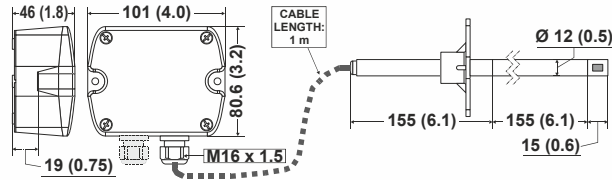

Fig. 1. Dimensions, AV-R-10, in mm (inches)

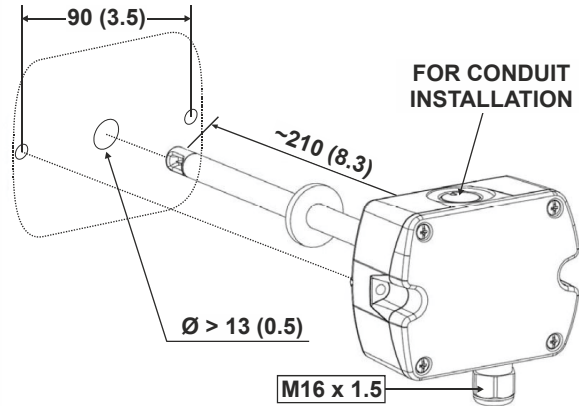

Fig. 2. Dimensions, AV-D-10, in mm (inches)

WIRING

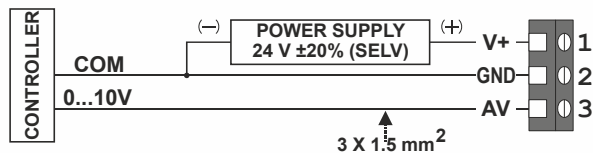

Fig. 3. Wiring

NOTE: Use shielded wiring in areas with high EMI. Keep 15 cm (5.9") minimum distance between sensor lines and 230 VAC power lines.

SETTINGS

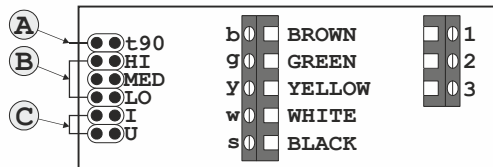

Fig. 4. Jumpers (A = response time; B = measuring range; C = output signal)

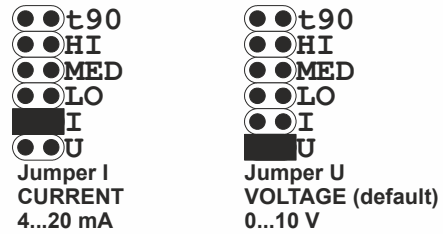

Fig. 5. Selection of output signal

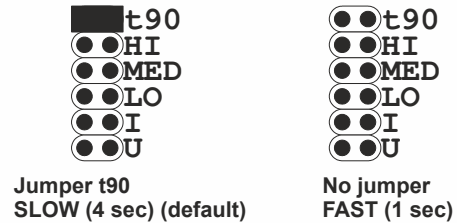

Fig. 6. Selection of response time

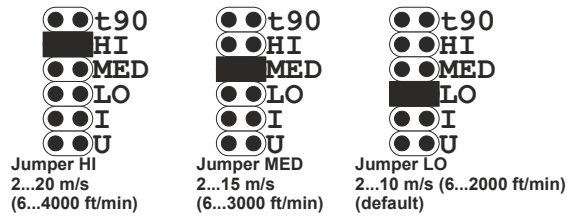

Fig. 7. Selection of measuring range

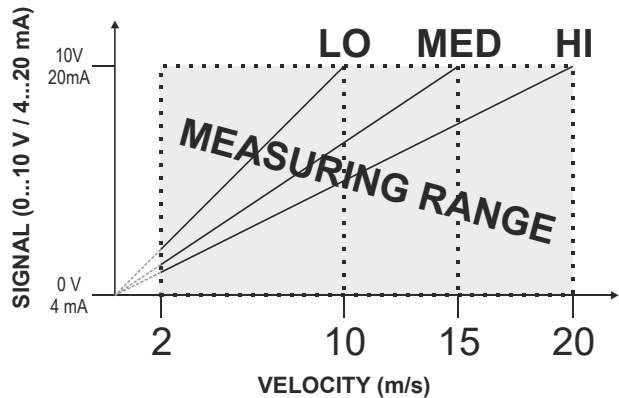

Fig. 8. Signal when jumper set to LO, MED, and HI



Manufactured for and on behalf of the Connected Building Division of Honeywell Products and Solutions SARL, Z.A. La Pièce, 16, 1180 Rolle, Switzerland by its Authorized Representative:

Home and Building Technologies
 Honeywell GmbH
 Böblinger Strasse 17
 71101 Schönaich, Germany
 Phone +49 (0) 7031 637 01
 Fax +49 (0) 7031 637 740
 http://ecc.emea.honeywell.com