



**CHILVENTO**  
18-19 OCTOBER 2018  
MALL 7 STAND 7-829



**LU-VE Group** is one of the major manufacturers in the world in the heat exchanger field.  
**The Group** (with HQ in Uboldo, Varese, Italy) consists of **12 manufacturing** facilities in **8 countries**:  
Italy, China, Czech Republic, India, Poland, Russia, Sweden and USA  
with a network of sales companies and representative offices in Europe, Asia, the Middle East, Oceania and USA.

More than **2,700** skilled employees

More than **390,000** sqm. total surface area

More than **160,000** sqm. covered area

**2,500** sqm. of R&D laboratories

More than **80%** of production exported to **100** countries

Consolidated turnover € **270.0** million (30.12.2017)

Listed on the **Milan Stock Exchange**





Based close to Milan (Italy) TGD produces glass and glass door components for the commercial, professional, industrial and scientific refrigeration market. It was founded in 1999 and it became an active part of the LU-VE Group in 2014

**“ Our aim is to offer our customers highest efficiency solutions to reduce the energy consumption of their products, increasing their commercial value. This is how we comply with our mission to contribute in making a better world”**

TGD has obtained 6 patents during its lifetime: a patent is the highest prize for any research and development activity. It is proof that the target has been achieved in a more innovating, quicker and efficient way than anybody else has been able to do.

Our experience and innovating capability is dedicated to all partners, to let them take advantage of the best realisation of their projects.

<b>Foundation</b>	1999
<b>LU-VE Group incorporation</b>	2014
<b>Employees</b>	100
<b>Patents</b>	6



# Lt 0 Energy door



“0 Energy” door **cuts the energy consumption** of any wall freezing display



It allows better product presentation due to its **immediate anti-fog performance** when the door is opened



**The highest payback on your investment**

Traditional freezing display glass doors are provided with heaters in order to:

**Avoid condensation** in case of high environment humidity

**Reduce** moisture on the inner glass surface when the door is opened to pick of displayed products

Average energy consumption of any full height traditional door is about **150 W/sqm.**

Unless “Trim Heaters” or other energy cut-off devices are installed on the cabinet, which in any case are known to significantly reduce life expectation of all heating elements, energy is supplied to glass doors 365 days a year and 24 hours a day

---

**The master frame of 0 Energy doors is made of a special combination** of various materials with different thermal conductivity, able to stop cold migration to the aluminium external surface

The transparent section is made of **high performance heat reflective glass layers**, joined by warm edge having an extremely low cold transfer rate ( $U_g=0.16$ ).

Both factors take the whole **insulated glass unit Ug value down to = 0.8**

**Such special features make TGD 0 Energy doors comply with EN44 1 standard class 3, without any need for electrical anti-condensing devices**



Don't think further, just go for "0 Energy"!



# Cost Saver



Cost Saver is the brand new line-up master frame for freezing applications with **optimized energy saving feature**



Low energy frame is available as an enhancement option to the standard heating product. Same aesthetics, same dimensions, **much higher value and payback for your appliance**



Cost Saver frame has an incredible number of **technological advantages** when compared to any of the standard heating frames available on the market

## Energy saving performance on standard dimension products

Description	STD version total power/watt	E.S. version total power/watt	VOLT
Frame 2 door dim. 1564x1639mm	263	130	230
Frame 3 door dim. 2342x1639mm	389	195	230
Frame 4 door dim. 3123x1639mm	515	260	230
Frame 5 door dim. 3898x1639mm	641	320	230
Frame 2 door dim. 1564x1844mm	278	140	230
Frame 3 door dim. 2342x1844mm	411	205	230
Frame 4 door dim. 3123x1844mm	544	272	230
Frame 5 door dim. 3898x1844mm	677	335	230

Cost saver frame permits **saving at least 50% of the energy** needed by any standard frame to safely guarantee EN441 class 3 compliance



The highest payback on your investment!



# E-Cut Total Look



**Full transparent mullions** allowing the best selling products visibility from any perspective



The best energy saving solution for big retail shops with **long fresh food corridors**



The only full transparent doors with **certified reliability and durability**



# E-Cut Total Look technical datasheet

"E-cut Total Look" is the door system for top cooling appliances, with fully transparent insulated glasses

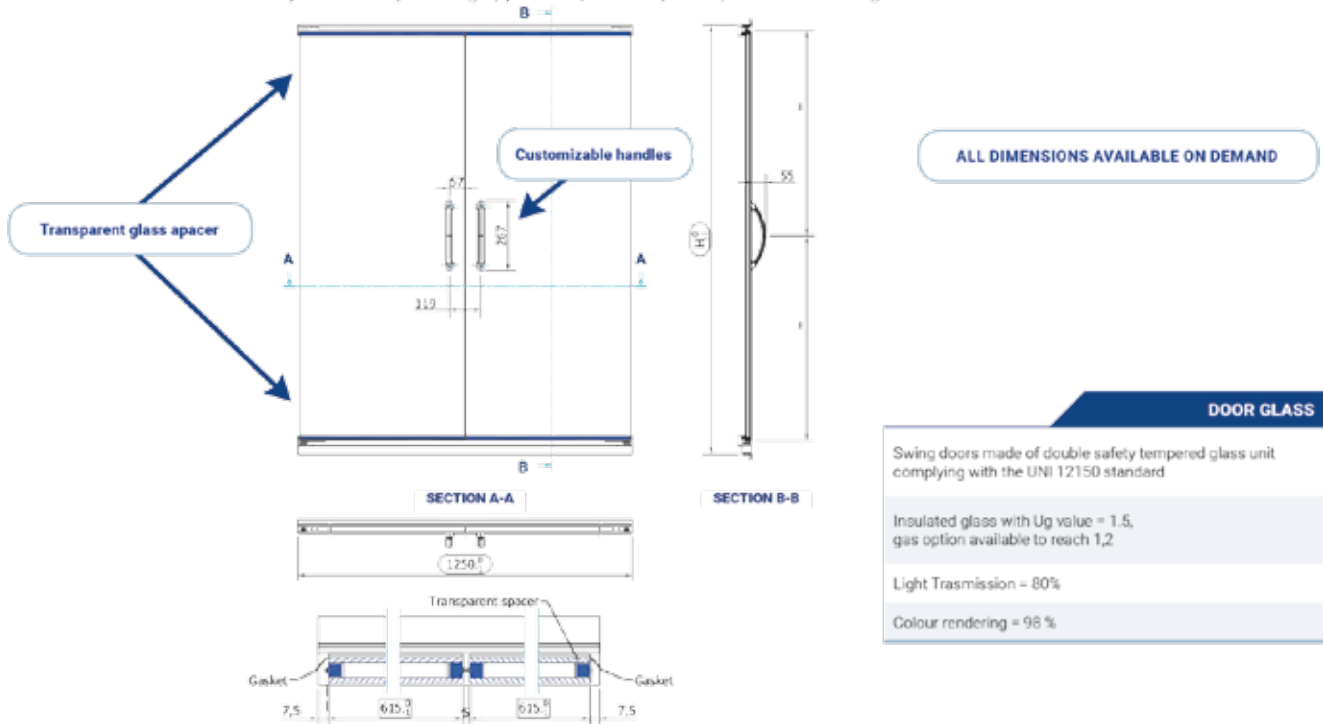

The E-Cut insert target is **to reduce up to 50% of the energy consumed** by open front multideck appliances



Don't think further, just go for the Total Look!



# E-Cut Wide Look

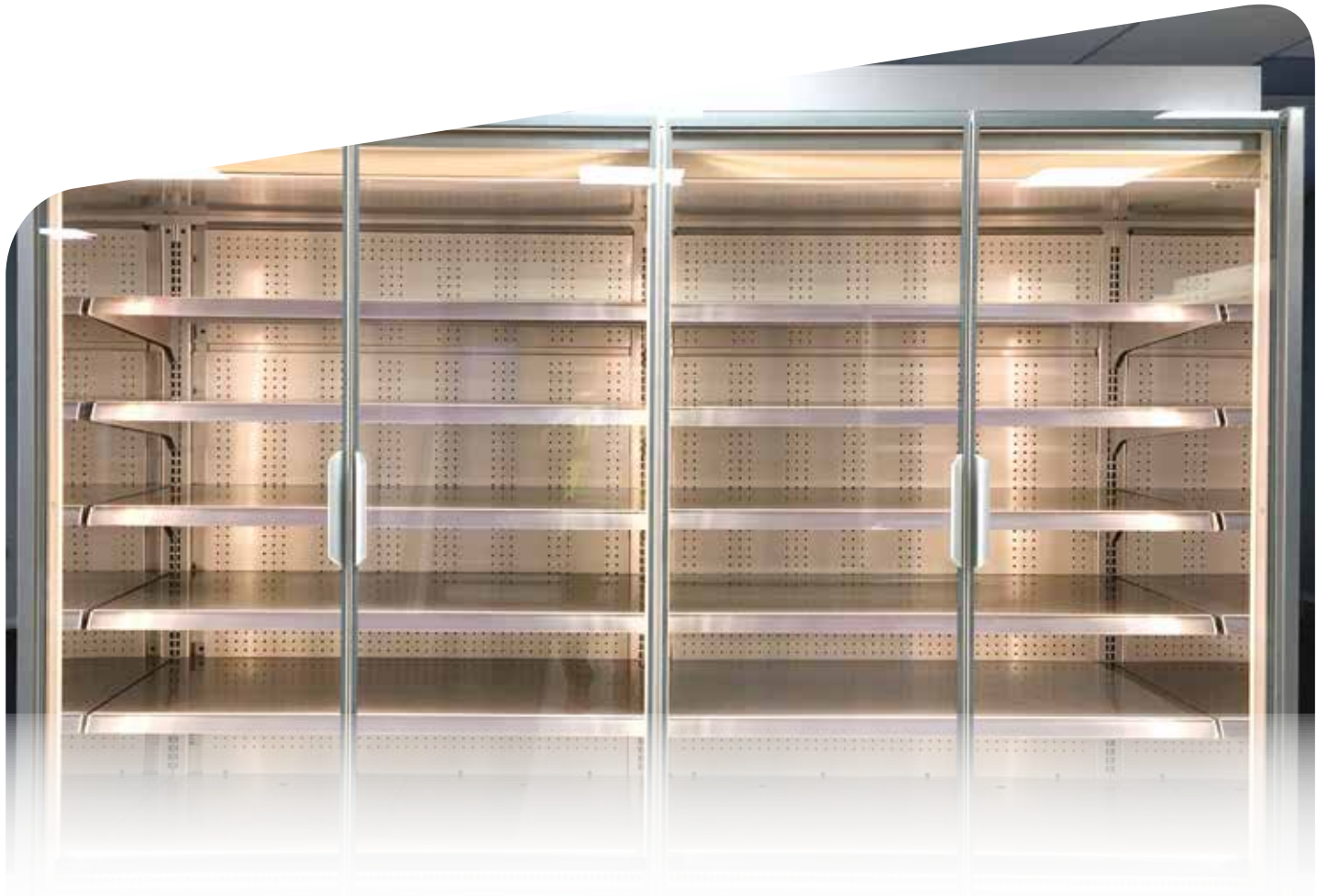

- Attractive appearance, profiting from full glass doors which completely **hide the overall structure of the appliance**
- **High energy efficiency**, thanks to the perfect combination of brilliant “0 Energy” frame solutions and the latest generation of “Full Glass Doors”
- **Superior reliability**, due to the extensive TGD experience in providing similar solutions to all major players in the retail market.

# E-Cut Wide Look technical datasheet

**Pro-Vision** with the door exceeding the frame on the top side, providing your cabinet of a unique full glass outlook

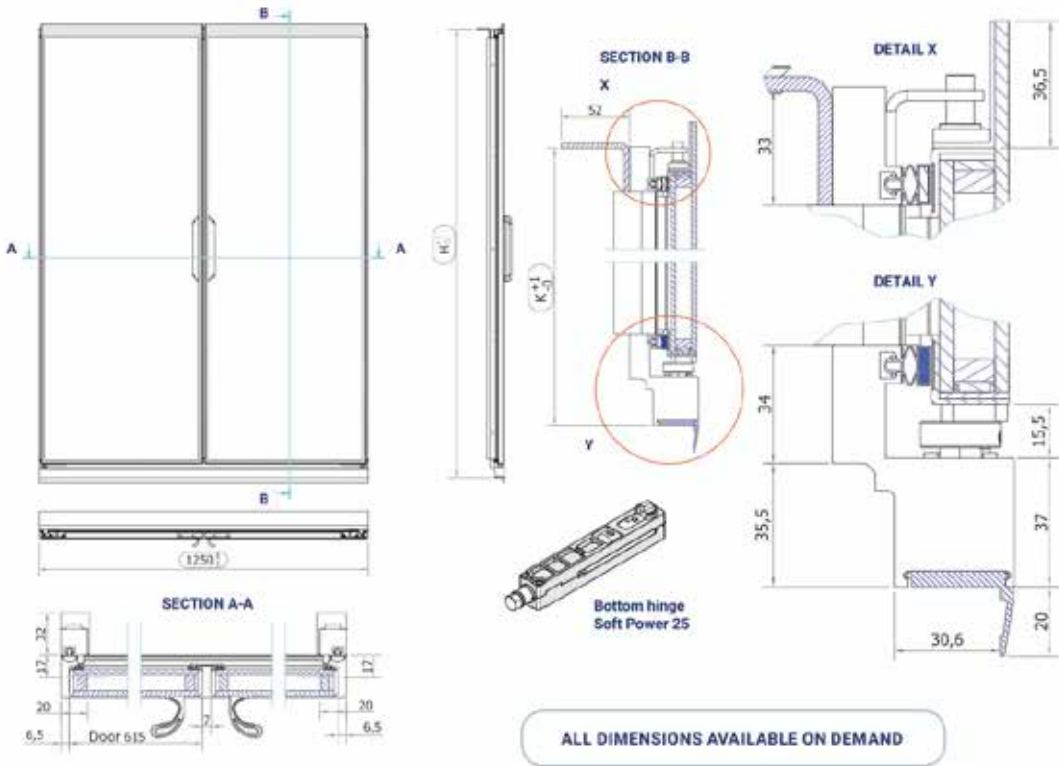

ALL DIMENSIONS AVAILABLE ON DEMAND

DOOR GLASS	
Swing doors made of safety tempered double glazing glass complying with the UNI 12150 standard	
Silk screened external glass layer	
1.3 U <sub>g</sub> Value insulated glass	
80% Light transmission	
98% colour rendering	
FRAME	
PVC supporting frame in reinforced aluminium, RAL 7035 or RAL 7015 PVC coloured frame	
Modular concept: frames can be alternated according to any possible trunking of display cases	
Led equipped or Led predisposed	
Patented adjustable Soft Closing device	
Maintenance free	

The E-Cut insert target is **to reduce up to 50% of the energy consumed** by open front multideck appliances



Don't think further, just go for the Wide Look!



# Wide Look Lt



The only Low Temperature Full Glass Door which completely **hides the overall structure of the appliance**



**High energy efficiency**, thanks to the perfect combination of brilliant “Low Energy” frame solutions and the latest generation of 0 Energy “Full Glass Doors”



**Superior reliability**, thousands of products operating in the market

# Wide Look Lt technical datasheet

"Wide Look Lt" is the glazed insert from TGD specifically engineered for freezing top appliances of the most advanced retail industry suppliers.

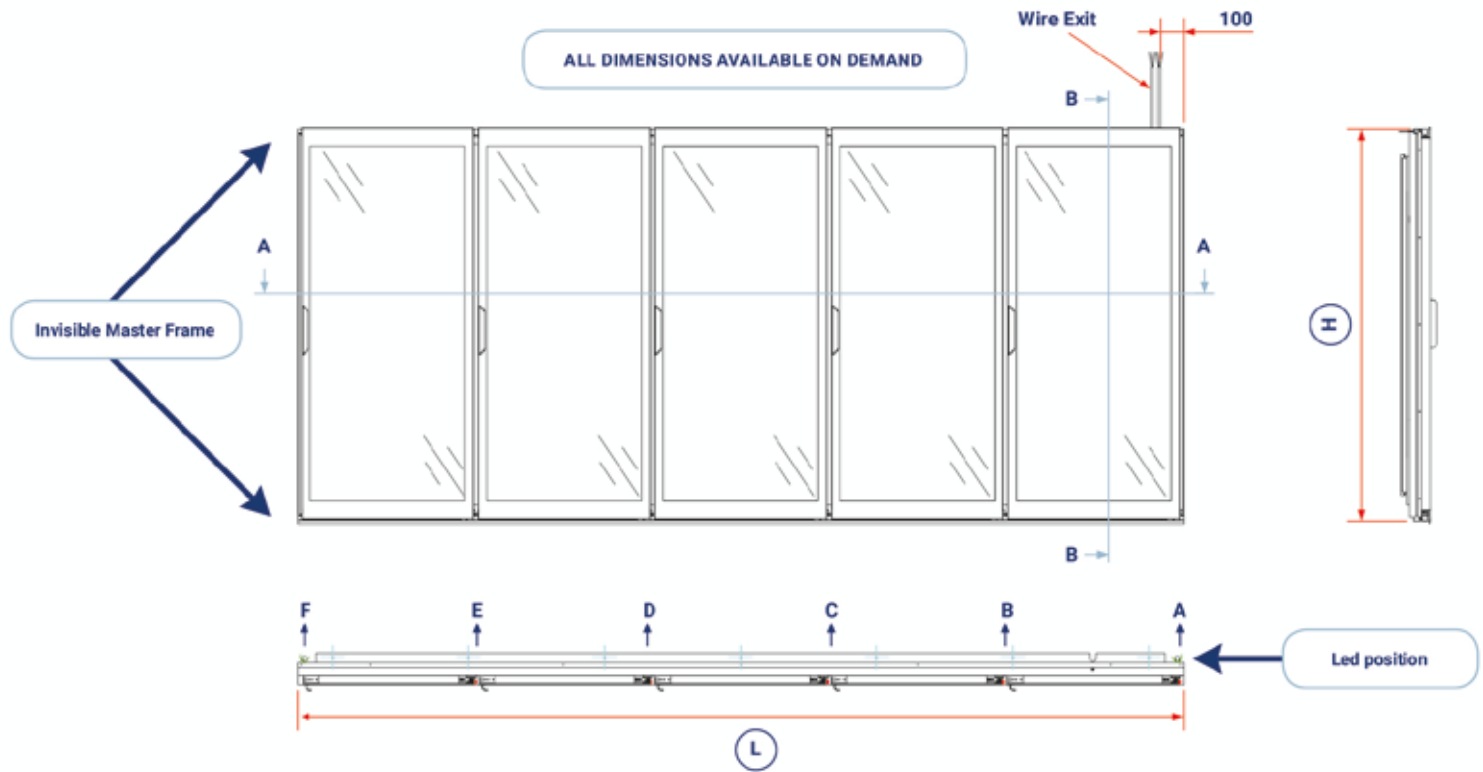

Wide Look LT: **the most beautiful, the most reliable**



Don't think further, just go for the E-Cut!



# Green Gas Heated Frame

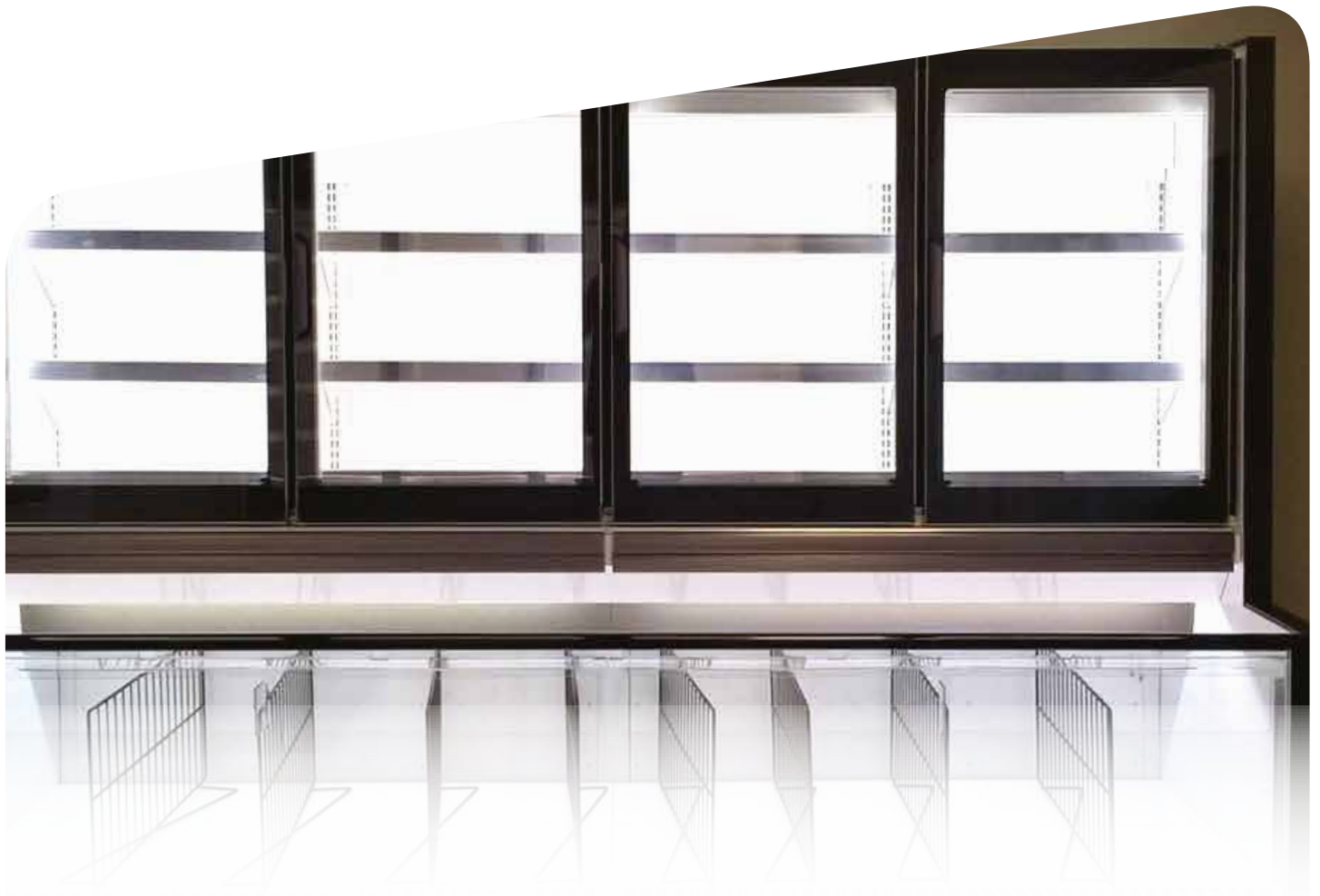

- **The Energy Saving glazed insert** from TGD specifically engineered for plug-in top freezing appliances
- Out of the condensing unit, the warm refrigerant fluid is canalised inside the frame **avoiding the need for electrical heaters**
- Higher efficiency thermodynamic circuit, **stronger benefit for the end user**

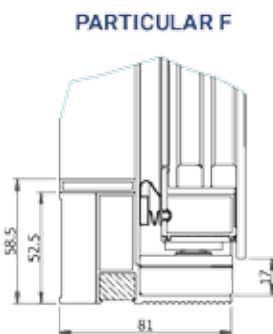
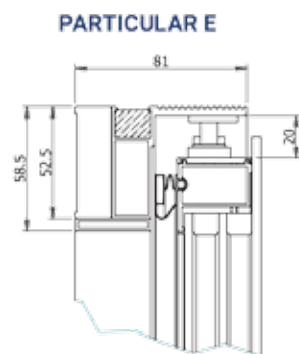
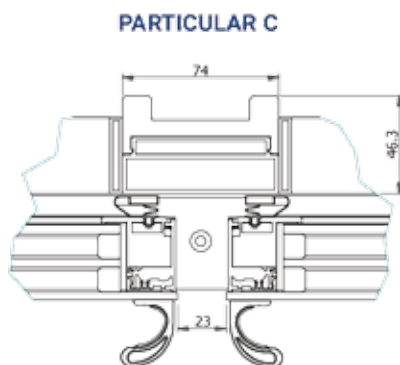
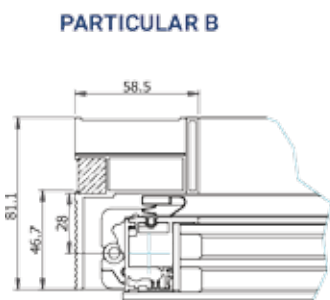

**GLASS DOOR**

- Swing door made of "0 Energy" safety triple glass
- Silk screened external glass layer
- Internal glass antifog treatment
- UNI 12150 and UNI 23953 class 3 complying component
- 0.7 Ug insulated glass
- 76% Light transmission
- 97% Colour rendering
- Patented adjustable self closing device 500.000 cycles tested

**MASTER FRAME**

- Natural gas defrosting technology
- LED Equipped or LED Prewired configuration
- Uni 23953 Class 3 tested components
- Maintenance free

The **Green Gas** heated frame combines the retail trend to prefer plug-in units using low GWP refrigerants, with a smart solution for using the same gas to **reduce electrical** anti defrosting heaters use



Don't think further, just go for the "Full Green Energy Saving Technology"!



# Smarter Vision door

The advertising revolution



## The Internet of Things (IoT) is here



### Smart factor

Be different!



### Brand reputation

Innovate!



### Consumer engagement

Keep the customer happy!



### Big data

Know more about your customers!



## Audience measurement system



How many people are in front of the Realook® Fridge



How many people interact with the Realook® Fridge and for how long



Gender



Age (4 age groups)



How many times users open the Realook® Fridge

## Activities



Play games on the screen



NFC/RFID fidelity card activities



Unlock special offers with NFC tags



Start the interaction with the proximity sensor



Mobile social engagement



**A team of experts to develop and personalise media to optimize Smarter Vision door activity and feedback**



# Digital Signage Innovating Devices



**iHOTEL**

**DIGITAL MIRROR**

**GATEWAY**  
The IoT Mirror for Lift Cars

- **Smart mirror tv:** the mirror becomes a tv able to communicate with the user and the outside via the web
- **Communication and digital signage:** the mirror becomes a device transmitting information, photographs, videos, advertising
- Configuration and playlist refresh can be operated by remote in **real time**

# Accessories



- High efficiency **LED selection** to improve selling products visibility
- **Patented reliable soft-closing system hinges** with closing force and speed regulation
- Wide range of customised high-**fashion handles**

