

High Efficiency Centrifugal Oil Separators WC&FC / A-WC & A-FC

General Information

The function of oil separator is the separation of oil from hot gas of discharge line and returning it back to the compressor or to the oil reservoir in systems with multiple compressors.

Application

- Multiple compressor racks for supermarkets and air conditioning.
- Systems with long refrigerant lines
- Systems with inherent oil return problems
- Ultra-low temperature systems
- For use with CFCs, HCFCs, HFCs and their lubricants

Nomenclature

Example: A-FC 8241717H

A	F	C	8	24	17	17	H
Series	F= Flanged W= Welded	Centrifugal	Diameter (in)	Length (in)	Inlet Connection in 1/8"	Outlet Connection in 1/8"	5" Legs Standard H=10" Legs

Features

- Internal Oil collection screen.
- Hermetic welded or accessible bolted flange construction.
- Solid steel connections.
- Corrosion resistant epoxy powder paint.
- High efficiency (99%) centrifugal separation.

Specifications

Maximum working pressure:

Welded Units 600 psig.
 Flanged Units 450 psig.

cUL. Listed (SA 8547)

Safety Instructions

- Read installation instructions thoroughly, Failure to comply can result in device failure, system damage or personal injury.
- It is intended for use by persons having the appropriate knowledge and skill. Before attempting to install the shell make sure pressure in system is brought to and remains at atmospheric pressure.
- Do not release any refrigerant into atmosphere.
- Do not use any other fluid media without prior approval of Emerson Climate Technologies Flow Controls Division / Applications Engineering Department. Use of fluid not listed could result in change of hazard category of product and consequently change of conformity assessment requirement for product in accordance with European pressure equipment directive 97/23/EC or Countries were applied.
- In a severely contaminated system, avoid breathing acid vapors and avoid contact with skin from contaminated refrigerant/lubricants. Failure to do so could result in skin injury.
- The oil separator must be used only for the purpose it is designed.

Mounting Location

The oil separator should be installed as close as possible to the compressor (s) in the main discharge line but after any installed muffler or vibration eliminator.

Prevent the migration of liquid refrigerant back into the oil separator shell during off-cycles by one of the following recommendations:

- Install the oil separator in a location where it is higher than condenser.
- If the oil separator located slightly lower than condenser install the line from oil separator to the condenser at higher level than the condenser and with a downward slope into the condenser inlet connection.
- In systems which the condenser located higher than the oil separator, it is recommended the use of a check valve at outlet of oil separator.

Warning

- Protect the oil separator against vibration and gas pulsation generated by compressor. Install the vibration eliminator and muffler between compressor and oil separator.
- When brazing, direct flame away from shell. Use wet rags or other suitable heat protection to prevent damage to the paint surfaces adjacent the fittings.
 - Use correct temperature for silver brazing of copper to steel as the fittings of shell are solid steel. Do not exceed 675°C flame temperature.
 - The uses of dry nitrogen through lines during brazing will prevent the oxide scale (solid particles) forming on the inside of the brazed joints. These particles can jam the float mechanism or clog the needle valve.
- Caution:** The oil separator F Type with flange cap is incorporated a gasket. Do not exceed +150°C around flange. If so, the gasket can be destroyed and it must be replaced. Keep the flange cap cool.
- The oil return line (minimum 3/8" or 10 mm tube) should be connected to the compressor crankcase or to the oil reservoir in the systems with multiple compressors.
 - If the piping result in excessive stress to the joints of oil separator, the pipes must be supported by suitable mounting bracket(s).

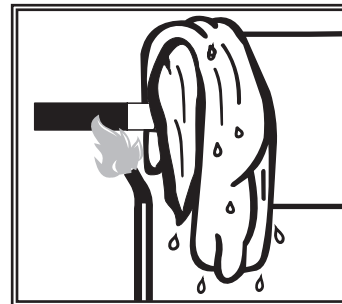

Installation

Before proceeding with the installation, the oil separator must be charged with certain amount of oil in order to actuate the float mechanism immediately after start-up. Use the same type of oil as filled in the compressor crankcase.

- 0.5 Liter (17 oz) Initial Oil Charge for WC/FC & AWC/AFC - 4 xx
- 0.6 Liter (21 oz) Initial Oil Charge for WC/FC & AWC/AFC - 6 xx, -8 xx, -10xx, -12 xx
- The oil must be charged through outlet connection.
- The oil separator shell must be mounted securely in a vertical position.

Leakage Test

- After completion of installation, a test pressure must be carried out as follows:
 - According to EN378 for systems which must comply with European pressure equipment directive 97/23/EC.
 - To maximum working pressure of systems for others applications.

Warning

- 1) Failure to do so could result in loss of refrigerant and person injury.
 - 2) The pressure test must be conducted by skilled persons with due respect regarding the danger related to pressure.
- In case of detection of leakage around flange of oil separators Flanged Type, check the gasket and the tightness of bolts with 35 Nm torque. A spare gasket is supplied with each Flanged Type Oil separator.
 - After leakage test, the unused spare gasket should be taped or hanged in a position near oil separator for use when it is required.

Operation

- After leakage test, start system. The oil level in compressor Crankcase and in Oil Reservoir must be watched after start-up, the first hours of operation and few days later. The new refrigerant will adsorb some oil. A small portion of oil may be trapped in the system somewhere in lines or heat exchangers.
- The oil separator removes the excess oil but this may not be retained in compressor crankcase immediately. In normal operation, the oil return line to the compressor crankcase or to the Oil reservoir which will be alternatively hot and cold.
- This is caused by opening and closing of the needle valve via lifting and lowering of the float mechanism.
- In outdoor installation at low ambient temperatures, the oil separator may be needed to be protected against cold stream of air in order to prevent the condensation of refrigerant will be sent through oil return line into the compressor crankcase, creating foam in the oil and causing lubricant problem.
- Oil separators perform best when operating at or near the compressor discharge temperature. It is advisable to insulate the oil separator shell.

Warning

During operation of system, the shells have a high surface temperature.

Service Hints

- Oil separator F type are equipped with flange and can be opened for cleaning. Always use a new gasket and tight the bolts with 35 Nm. torque.
- The external surface of shells is coated by epoxy powder painting for optimum protection against corrosion. The external surface of shell shall be checked as per EN-378 during routine / periodic inspection / service.

ORDERING INFORMATION AND CAPACITY TABLE

Model	Solder Connection Size (ODF)	Style Number	Shell O.D.	MAXIMUM CAPACITY IN TONS OF REFRIGERATION AT EVAPORATOR TEMPERATURE										Maximum Discharge CFM	Oil Pre-Charge Amount (oz.)					
				R-134a		R-22		R-407C		R-404A		R-507				R-410A				
				-40°F	+40°F	-40°F	+40°F	-40°F	+40°F	-40°F	+40°F	-40°F	+40°F			-40°F	+40°F			
A-WC 41777	7/8	1	4"	5	6	7	8	7	8	6	8	7	9	11	12	6	17			
A-WC 41999	1-1/8			5	7	8	9	8	9	7	10	8	10	13	14	7				
A-WC 6181111	1-3/8	4	6"	12	15	19	21	18	21	17	22	18	23	29	33	16	21			
A-WC 6181313	1-5/8			14	17	22	25	21	25	20	26	21	27	34	38	19				
A-WC 6181717	2-1/8			14	17	22	25	21	25	20	26	21	27	34	38	19				
A-FC 6221111	1-3/8			12	15	19	21	18	21	17	22	18	23	29	33	16				
A-FC 6221111H	1-3/8	2	6"	12	15	19	21	18	21	17	22	18	23	29	33	16	21			
A-FC 6221313	1-5/8			14	17	21	24	20	24	19	25	20	26	33	37	18				
A-FC 6221313H	1-5/8			14	17	21	24	20	24	19	25	20	26	33	37	18				
A-FC 6221717	2-1/8			15	18	23	25	21	25	20	26	21	28	34	39	19				
A-FC 6221717H	2-1/8			15	18	23	25	21	25	20	26	21	28	34	39	19				
A-FC 8241717	2-1/8			3	8"	23	28	36	40	33	40	32	42	34	43	54		62	30	21
A-FC 8241717H	2-1/8	23	28			36	40	33	40	32	42	34	43	54	62	30				
A-FC 10242121	2-5/8	10"	10"		46	56	71	80	66	79	63	83	68	87	108	123	60			
A-FC 10242121H	2-5/8				46	56	71	80	66	79	63	83	68	87	108	123	60			
A-FC 12302525H	3-1/8				12"	12"	73	89	113	127	105	125	100	132	107	138	172	195	95	
							73	89	113	127	105	125	100	132	107	138	172	195	95	

DIMENSIONAL DATA

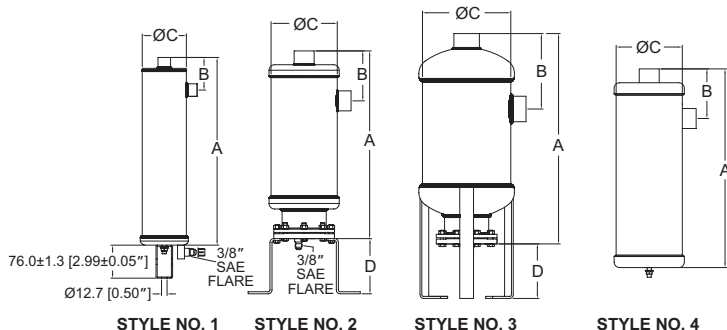

MODEL NUMBER	CONNECTION	STYLE NO.	DIMENSIONS						
			A	B	ØC	D			
A-WC 41777	7/8"	1	17.01	2.95	4.0	-			
A-WC 41999	1-1/8"		19.02	3.07					
A-WC 6181111	1-3/8"	4	18.0	3.93	6.0				
A-WC 6181313	1-5/8"			4.52					
A-WC 6181717	2-1/8"			4.65					
A-FC 6221111	1-3/8"			17.0			3.94	5.0	
A-FC 6221111H		10.0							
A-FC 6221313		5.0							
A-FC 6221313H		10.0							
A-FC 6221717		5.0							
A-FC 6221717H		10.0							
A-FC 8241717	2-1/8"	19.06	6.83	8.0		5.0			
A-FC 8241717H					10.0				
A-FC 10272121					2-5/8"	22.10	6.11	10.0	5.0
A-FC 10272121H									10.0
A-FC 12302525H	3-1/8"	25.1	7.05	12.0	10.0				